





CO2 Rail Car Front Tire





A. Sketch Construction Lines.

Step 1. Click File Menu > New, click **Part Metric** and OK.

Step 2. Click **Front Plane**  in the Feature Manager and click **Sketch**  on the context toolbar, **Fig. 1**.

Step 3. Click **Centerline**  in the **Line flyout**  on the Sketch toolbar.

Step 4. Starting at the Origin  sketch a vertical centerline up from the Origin and a horizontal centerline out to left from Origin, **Fig. 2**. To terminate chain, double click back on the line you have just sketched.

Step 5. Click **Smart Dimension**  (S) on the Sketch toolbar.

Step 6. Dimension the vertical centerline 17, **Fig. 2**.

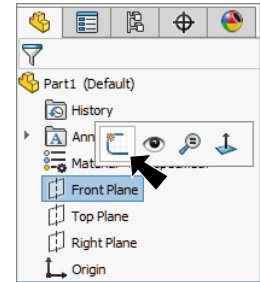

Fig. 1

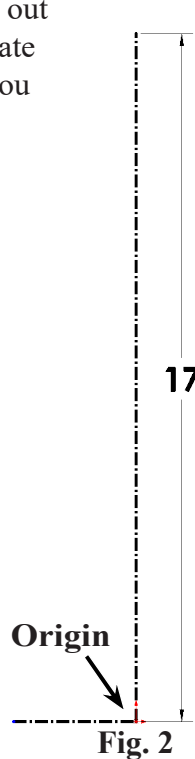

Fig. 2

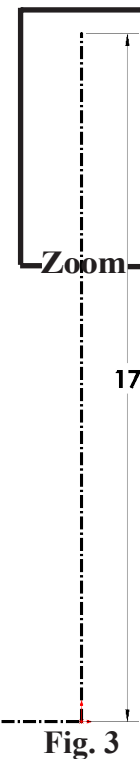

Fig. 3



B. Save as "FRONT TIRE".

Step 1. Click File Menu > Save As.

Step 2. Key-in **FRONT TIRE** for the filename and press ENTER.

C. 3 Point Arc.

Step 1. Zoom in at **top of vertical centerline**, **Fig. 3**. To zoom, place the cursor over top of centerline and spin the wheel on mouse back. While spinning the wheel keep cursor on top of line.

Step 2. Click **3 Point Arc**  (S) in the **Arc flyout**  on the Sketch toolbar.

Step 3. Sketch an arc between the Position 1, Position 2 and Position 3 in **Fig. 4**. To sketch the arc, first click Position 1, then Position 2. Swing the arc out to Position 3 and click.

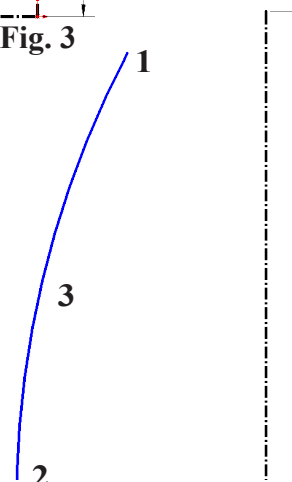



Fig. 4

Step 4. Click **Smart Dimension**  (S) on the Sketch toolbar.

Step 5. Add dimension. Dimension the arc radius 7 last and 3.7 to top endpoint of centerline, **Fig. 5**.

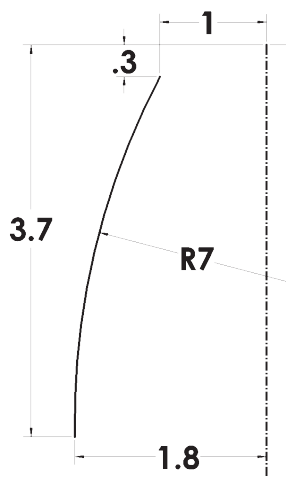

Fig. 5

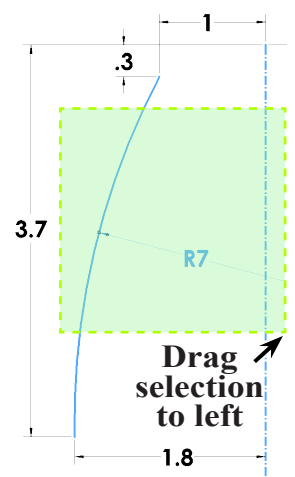

Fig. 6

D. Mirror Sketch.

Step 1. **Right click graphics area and click Select** from menu to unselect Smart Dimension.

Step 2. **Drag a “trend to left - more liberal” selection across arc and vertical centerline, Fig. 6.**

Step 3. Click **Mirror Entities**  on the Sketch toolbar, **Fig. 7**.

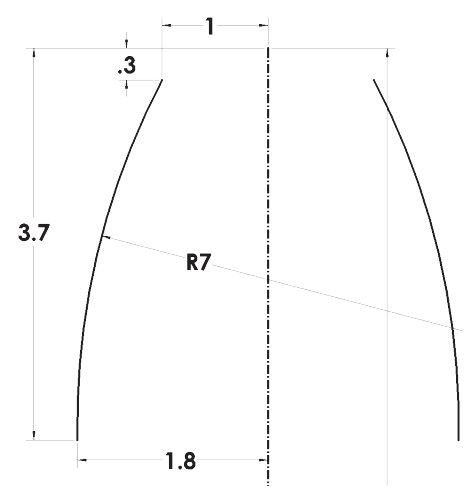



Fig. 7

E. 3 Point Arcs.

Step 1. Click **3 Point Arc**  (S) in the Arc flyout  on the Sketch toolbar.

Step 2. Sketch an arc between the top endpoints of arc and a second arc across bottom endpoints of arc, **Fig. 8**.

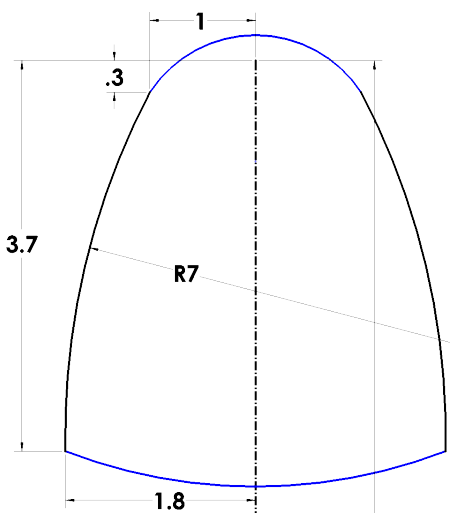



Fig. 8

Step 3. **Right click graphics area and click Select** from menu to unselect Arc Tool.

Step 4. **Ctrl click top arc and top endpoint of vertical centerline** to select both. Release Ctrl key and click **Make Coincident**  on the context toolbar, **Fig. 9**.

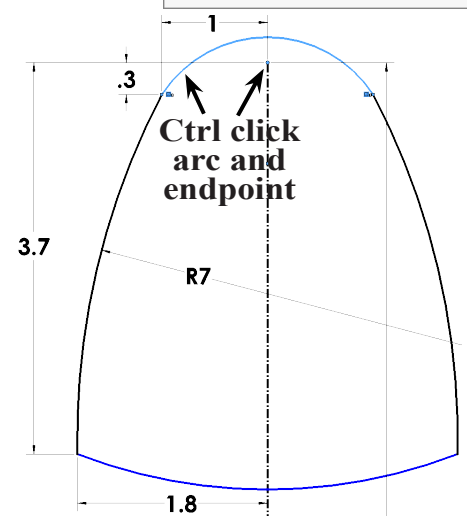

Fig. 9

Step 5. Click **Smart Dimension**  (S) on the Sketch toolbar.

Step 6. Dimension bottom arc **5**, Fig. 10.

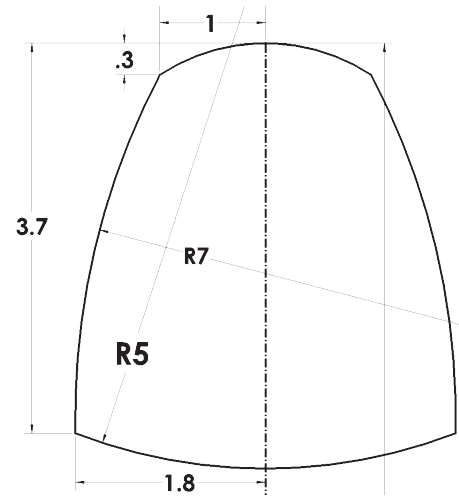

Fig. 10

F. Revolved Boss/Base.

Step 1. Click **Features**  on the Command Manager toolbar.

Step 2. Click **Revolved Boss/Base**  on the Features toolbar.

Step 3. In the Revolve Property Manger:

under Axis of Revolution 

click **horizontal construction line**, Fig. 12

Your bottom line of sketch does not have to show in Property Manager as Line1.

Click OK .

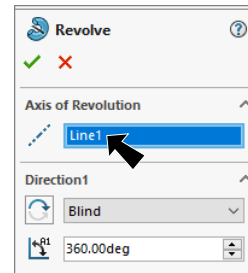

Fig. 11

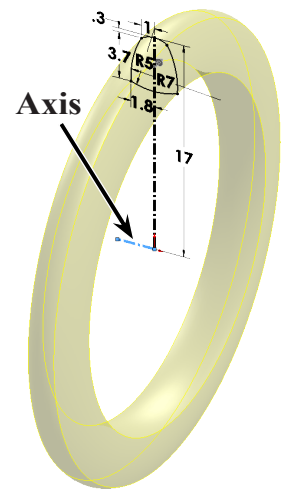

Fig. 12

Step 4. Click **Zoom to Fit**  (F) on the View toolbar.

Step 5. Save. Use **Ctrl-S**.

G. Material Rubber.

Step 1. **Right click Material**  in the Feature Manager and click **Edit Material**, Fig. 13.

Step 2. Expand **Rubber** in the material tree and select **EPDM 60 Durometer**. Click **Apply** and **Close**.

Step 3. Save. Use **Ctrl-S**.

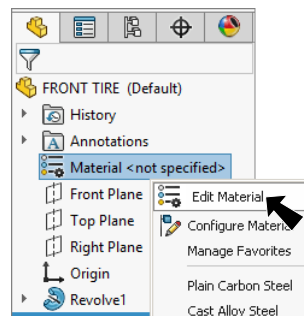

Fig. 13



Fig. 14