

# Rubber Band Belt

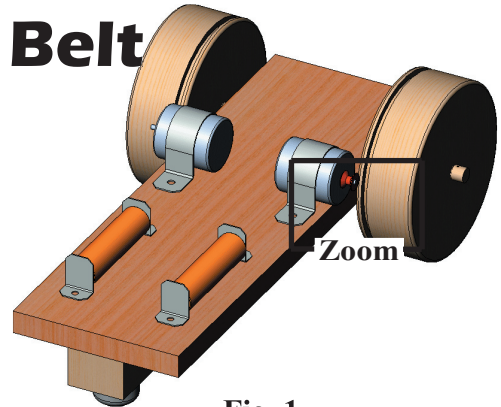



Fig. 1

## A. Create Belt.

Step 1. If necessary, open your SUMO CAR ASSEMBLY file.

Step 2. Click **Trimetric**  on the Standard Views toolbar (next to Isometric view).

Step 3. Use the **Zoom to Area**  in the View toolbar to drag a zoom window around the **pulley and wheel**, Fig. 1.

Step 4. Click Insert Menu > Assembly Feature > Belt/Chain.

Step 5. In the Belt/Chain Property Manager, under **Belt Members**:

click the **cylindrical face of the pulley**, Fig. 2 and the **cylindrical face of the bottom of the wheel groove**

under **Properties**:  
check **Engage belt**

check **Create belt part**

and click OK , Fig. 3 and Fig. 4

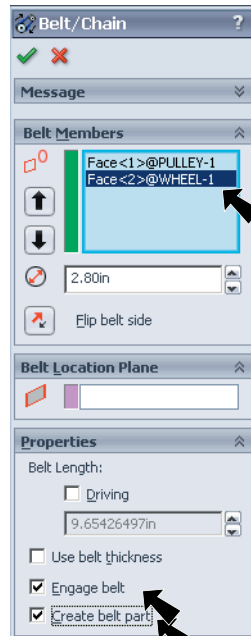

Fig. 3

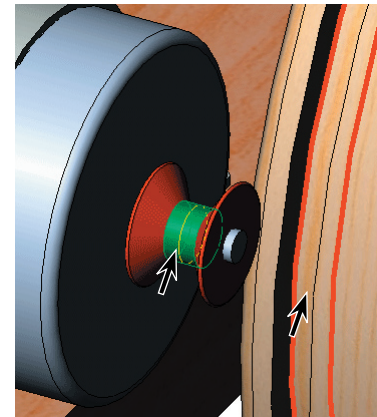

Fig. 2

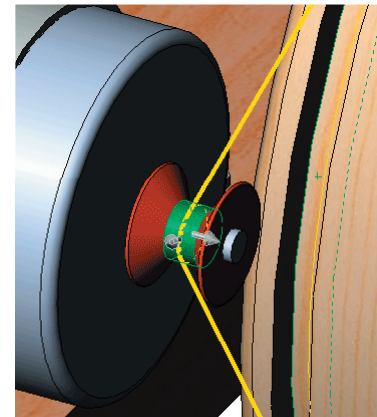



Fig. 4

## B. Extrude Belt Part.

Step 1. At the bottom of the Feature Manager design tree expand **Belt1** feature  **Belt1**, Fig. 5.

Step 2. Click **Belt1** part  **Belt1** and click **Open Part** , Fig. 5.

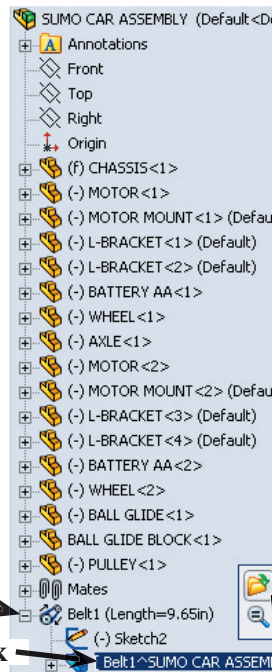
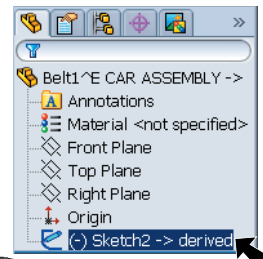

Fig. 5

Expand →

Click →

Step 3. Click the **Sketch** at the bottom of the Feature Manager, **Fig. 6** and click **Extruded Boss/Base** on the Features toolbar.



**Fig. 6**

Step 4. In the Extrude Property Manager, under **Direction 1** set:  
End Condition to **Mid Plane**

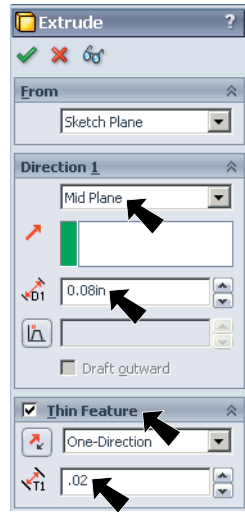

**Fig. 7**

**Depth** to **.08**

Check **Thin Feature**

under **Thin Feature** set:

**Thickness** to **.02**

and click **OK**, **Fig. 7** and **Fig. 8**.

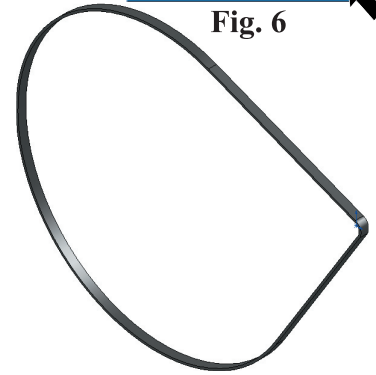
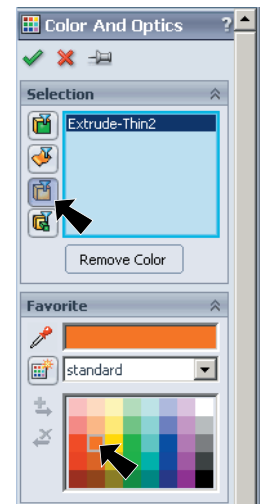

**Fig. 8**

### C. Appearance.

Step 1. Click Edit Menu > Appearance > Material.

Step 2. Scroll down Materials and expand **Other Non-metals**. Select **Rubber**, and click **OK**.



**Fig. 9**

### D. Color Orange.

Step 1. Click **Edit Color** on the Standard toolbar.

Step 2. Under Favorite: Click **Orange** swatch, **Fig. 9**.

Step 3. Click the rubber band and click **OK**.

Step 4. Save. Use **Ctrl-S**.

Step 5. Close the belt part file. Use File Menu > Close..

### E. Mate: Belt and Wheel.

Step 1. Click **Trimetric** on the Standard Views toolbar.

Step 2. Use the **Zoom to Area** in the View toolbar to drag a zoom window around the **belt and back wheel groove**, **Fig. 10**.

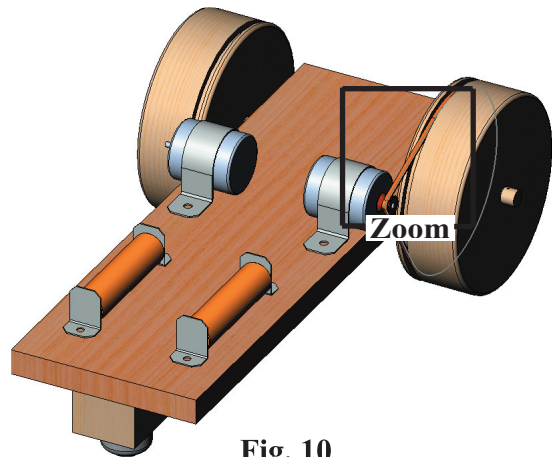



**Fig. 10**

Step 3. Press **F6** key on keyboard to turn off selection filters.

Step 4. Click **Mate**  on the Assembly toolbar.

Step 5. Click **side face of the wheel groove and left edge of the belt**, Fig. 11.

Step 6. Click Add/Finish Mate  to add **Concentric** mate. Click OK  when done.

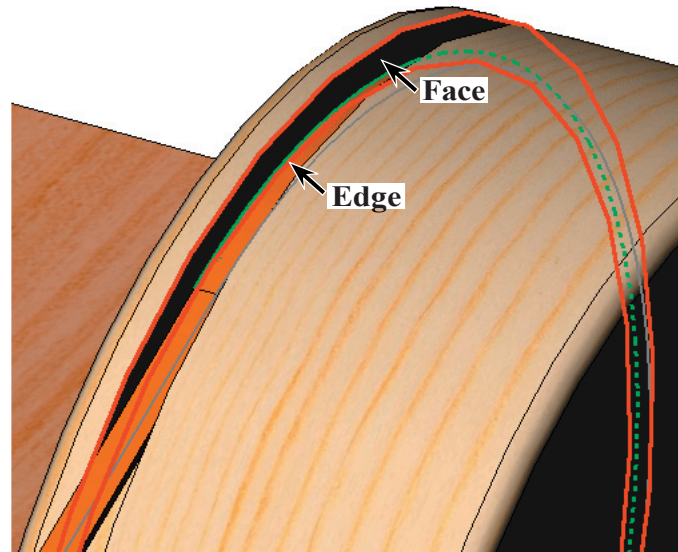
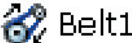

Fig. 11

## F. Hide Belt Sketch.

Step 1. Scroll down to the bottom of the Feature Manage design tree and **expand Belt1 Feature** 

Step 2. Click **Sketch1** and click **Hide** , Fig. 12.

Step 3. Save. Use **Ctrl-S**.

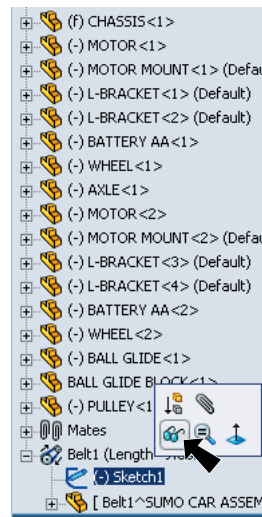

Fig. 12

## G. Mirror Pulley and Belt.

Step 1. Click Insert Menu > Mirror Components.

Step 2. Under **Selections**, **Mirror plane:**

Expand the Design Tree in the top left corner of the drawing area and select **Right** (plane), Fig. 13

Under **Components to Mirror:**

In the Design Tree, click to select **PULLEY**

**expand Belt1 Feature** 

**and select BELT part** , Fig. 13

**Check Recreate mates to new components,** Fig. 14

click OK  in the Property Manager, Fig. 16.

Step 3. Save. Use **Ctrl-S**.

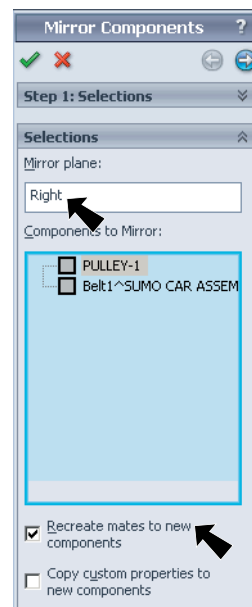

Fig. 14

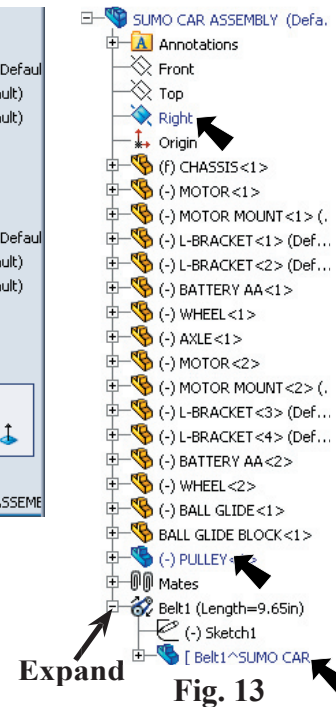

Fig. 13

