

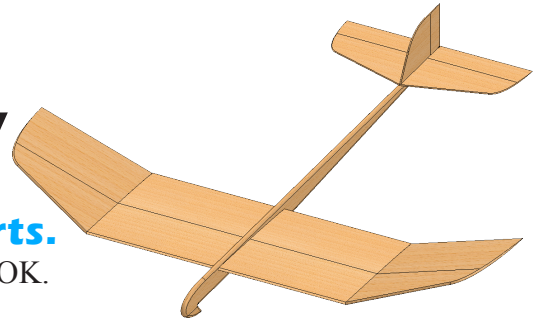



Glider Assembly Wing 2 Parts



A. Insert Fuselage and Shark Tooth Parts.

- Step 1. Click File Menu > New, click **Assembly Metric** and OK.
- Step 2. Click **Keep Visible**  in the Property Manager, **Fig. 1**.
- Step 3. Click **Browse** in the Property Manager, **Fig. 1**.
- Step 4. Select your **FUSELAGE** file and click Open.
- Step 5. Click OK  in the Property Manager. This will place Fuselage origin at the assembly origin and fix the position so Fuselage cannot move. This fixed component should have a **(f)** before its name in the Feature Manager  (f) FUSELAGE <1>.

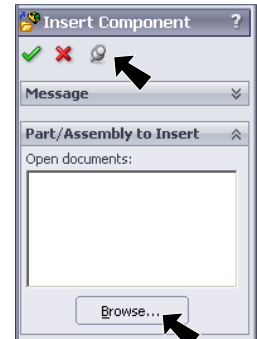

Fig. 1

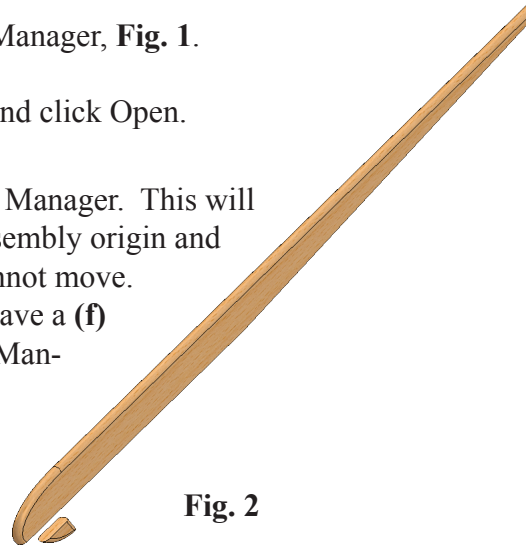



Fig. 2

- Step 6. Click **Browse** in the Property Manager, **Fig. 1**.
- Step 7. Select your **SHARK TOOTH** file and click Open.
- Step 8. Click approximately where the Shark Tooth is positioned in **Fig. 2**.
- Step 9. Click OK  in the Property Manager when done.

B. Save as "GLIDER ASSEMBLY".

- Step 1. Click File Menu > Save As.
- Step 2. Key-in **GLIDER ASSEMBLY** for the filename and press ENTER.

C. Mate: Fuselage and Shark Tooth.



- Step 1. Click **Mate**  on the Assembly toolbar.
- Step 2. Click **side face of Fuselage** and **side face of Shark Tooth**, **Fig. 3**.
- Step 3. Click Add/Finish Mate  in Mate pop-up toolbar to add a **Coincident** mate, **Fig. 4**.



Fig. 4

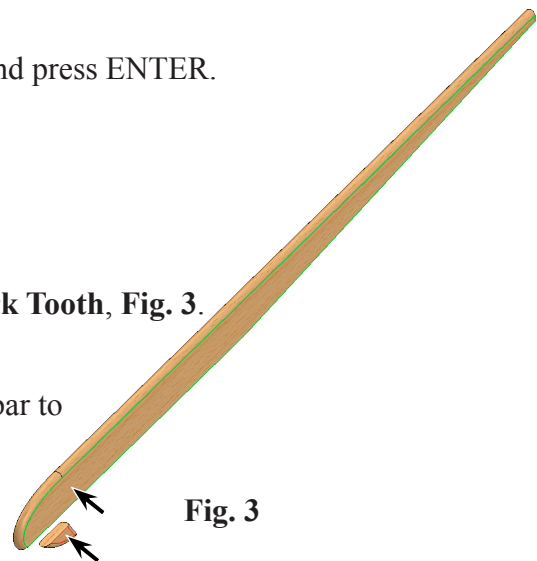

Fig. 3

Step 4. Pull the Shark Tooth back to the Fuselage. Be careful on to click the part as you pull it back, **Fig. 5**.

Step 5. Zoom in around **front of Fuselage and Shark Tooth, Fig. 5**. To **zoom**, hold down **Shift** key and drag with middle mouse button (wheel). To **pan**, hold down **Ctrl** key and drag with middle mouse button (wheel).

Step 6. **Right click side face of Fuselage** and click **Select Other** from the menu, **Fig. 6**.

Step 7. Click **bottom face of Fuselage, Fig. 7**.

Step 8. Click **top face of Shark Tooth, Fig. 8**.

Step 9. Click Add/Finish Mate  in Mate pop-up toolbar to add **Coincident** mate.



Fig. 5

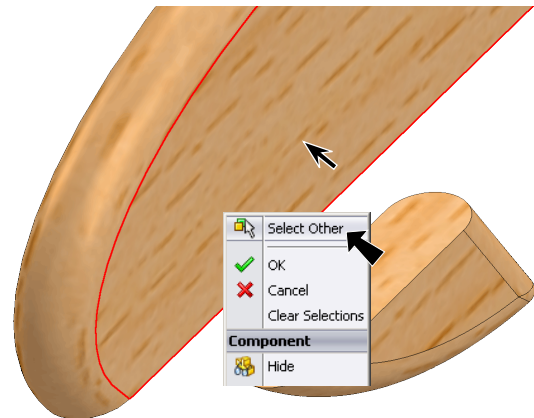

Fig. 6

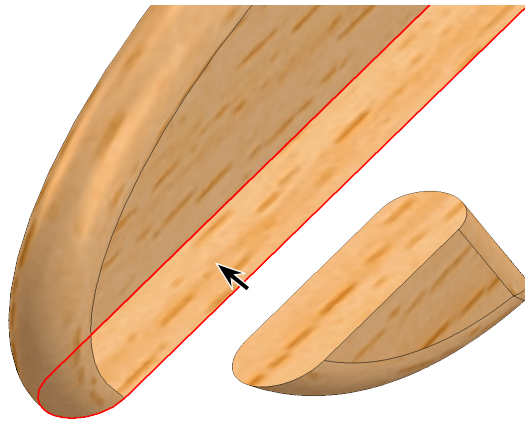

Fig. 7

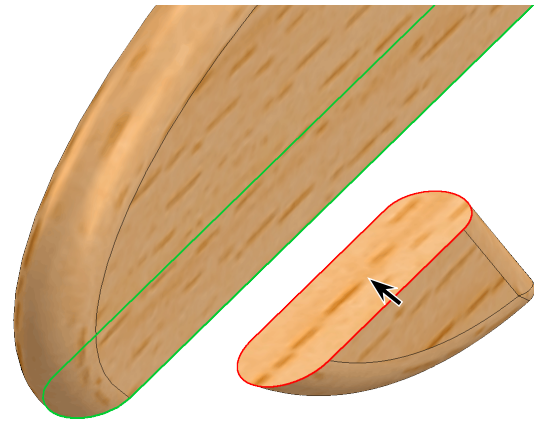

Fig. 8





Fig. 9

Step 10. Expand the Design Tree (click +) in the top left corner of the graphics area, **Fig. 10**.

Step 11. Click **Front Plane** , **Fig. 10**.

Step 12. Expand **Shark Tooth** and click **Front Plane** , **Fig. 10**.

Step 13. Click **Distance**  in Mate pop-up, **Fig. 10**. Set distance to **278** and click Add/Finish Mate  to add the **Distance** mate.

Step 14. Click **OK**  in the Property Manager when done.

Step 15. Save. Use **Ctrl-S**.

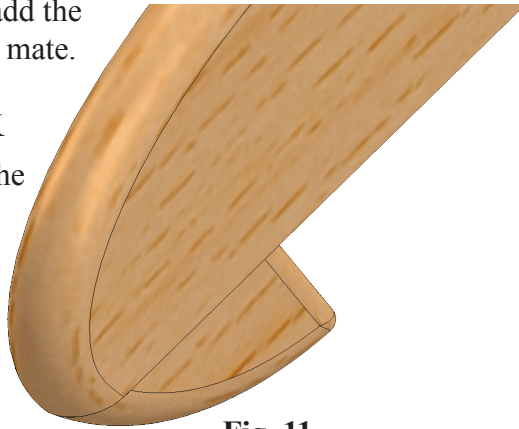

Fig. 11

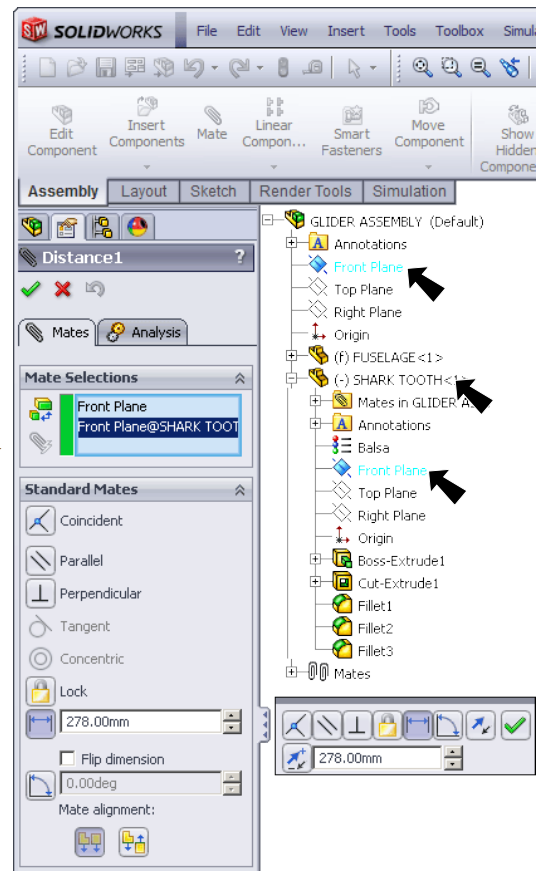

Fig. 10

D. Edit Part Convert Entities.

Step 1. Rotate view to view **bottom** as shown in **Fig. 12**. Hold down middle mouse button (wheel) and drag.

Step 2. Click the **Fuselage** and click **Edit Part**  on the Content menu, **Fig. 12**.

Step 3. Click the **bottom face** of the Fuselage and click **Sketch**  on the Content menu, **Fig. 13**.

Step 4. **Press Escape** key on keyboard to unselect the face.

Step 5. Click **Convert Entities**  on the Sketch toolbar.

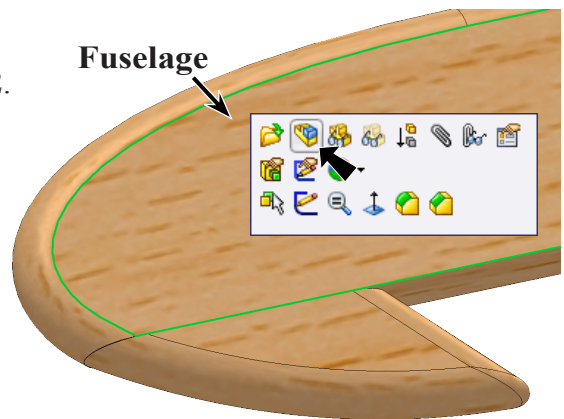

Fig. 12

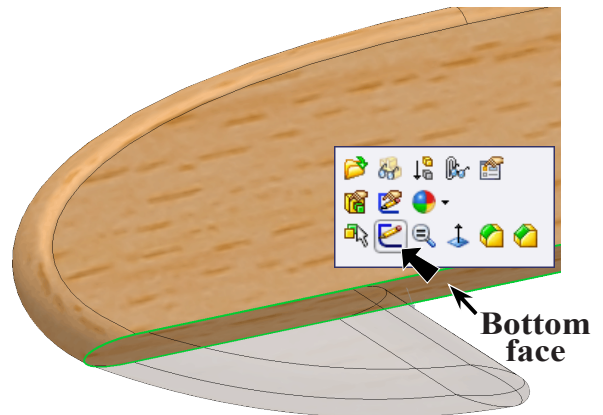



Fig. 13

- Step 6. In the Convert Entities Property Manager:
 click the **rear Fillet on the Shark Tooth**,
Fig. 14
 click OK  twice, **Fig. 14**.
 The sketch would look like **Fig. 16**.

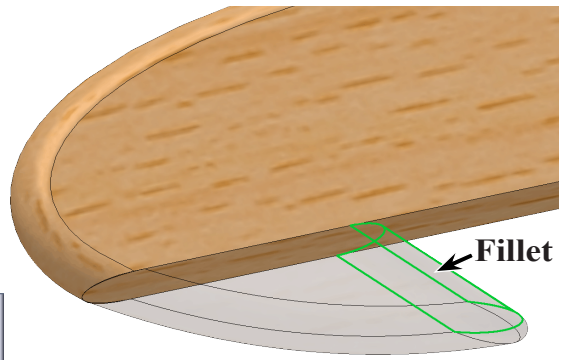
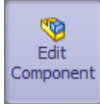

Fig. 14

- Step 7. Click **Edit Component**



on the Sketch toolbar to turn off edit component and return to the assembly file. You could edit the sketch here in the Edit Component, but we'll switch to the Part file.

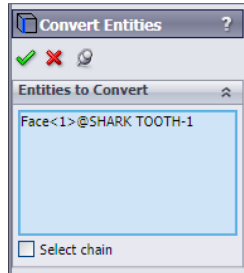

Fig. 15

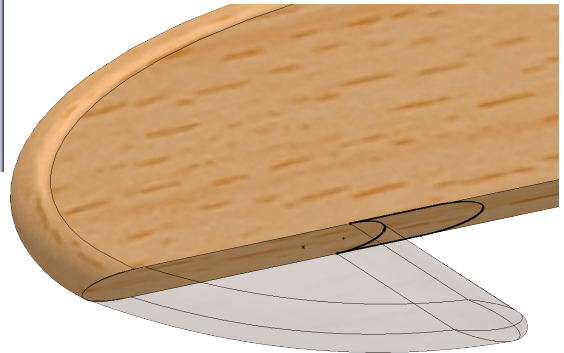



Fig. 16

- Step 8. Save. Use **Ctrl-S**.

E. Edit Part Edit Sketch.

- Step 1. Click the **Fuselage** and click **Open**

Part  on the Content menu,
Fig. 17.

- Step 2. Click **Sketch3** in the Feature Manager and click

Edit Sketch  on the Content menu, **Fig. 18**.

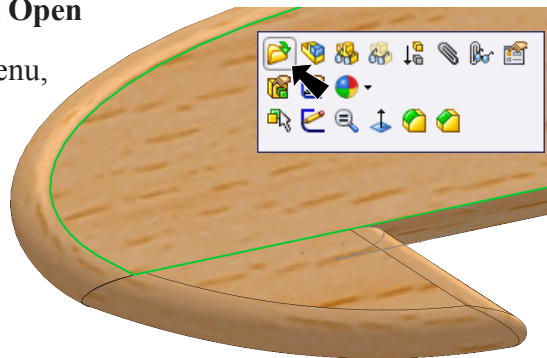

Fig. 17

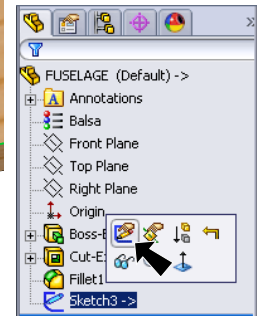

Fig. 18

- Step 3. Click **Normal To**  on the Standard Views toolbar. (**Ctrl-8**)

- Step 4. Click **Zoom to Selection**  (**Q**) on the View toolbar to zoom to sketch.

- Step 5. Click **Line**  (**L**) on the Sketch toolbar.

- Step 6. Draw a line across the Fuselage edges just below the ellipse, **Fig. 19**.

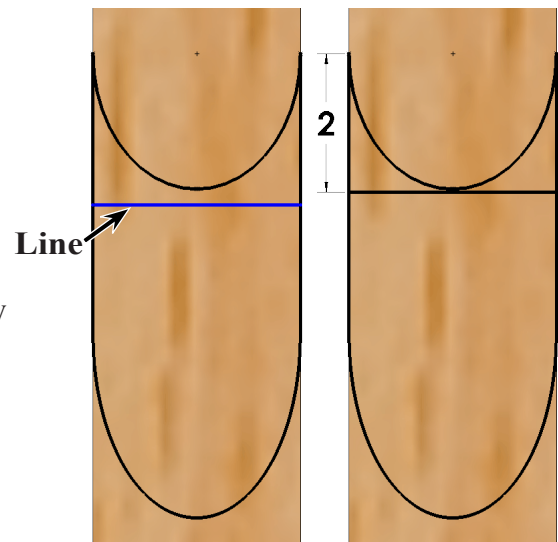

Fig. 19

Fig. 20

- Step 7. Click **Smart Dimension**  on the Sketch toolbar.

- Step 8. **Dimension 2** between line and top endpoint of ellipse, **Fig. 20**.

Step 9. Click **Trim Entities**  on the Sketch toolbar.

Step 10. In the Property Manger select:

Trim to closest , **Fig. 21**

Trim away the bottom of both vertical lines below horizontal line, **Fig. 22**. Click segments to remove (trim).

Click OK .

Step 11. Delete the **bottom spline**, **Fig. 23** and **Fig. 24**. To delete, click the spline and press Delete key.

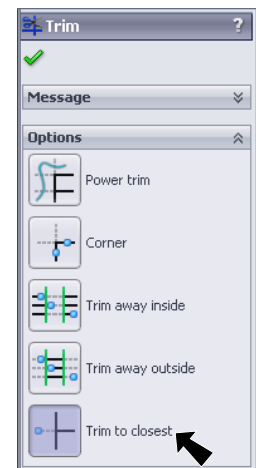
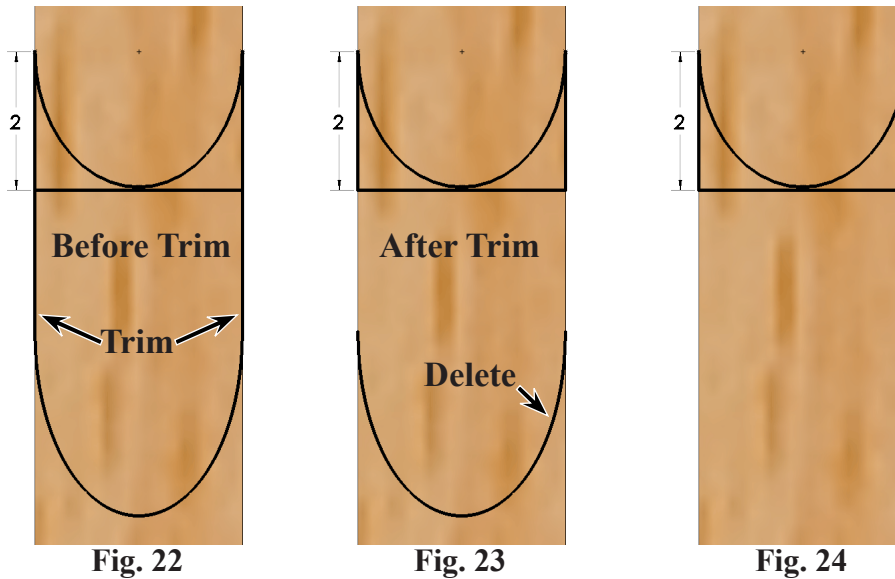
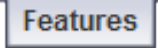

Fig. 21

F. Cut Revolve.

Step 1. Rotate view to view **side of Fuselage** as shown in **Fig. 25**. Hold down middle mouse button (wheel) and drag.

Step 2. Click **Features**  on the Command Manager toolbar.

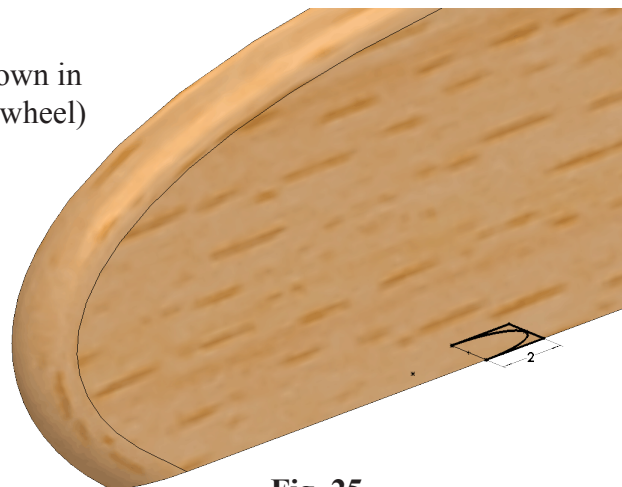



Fig. 25

Step 3. Click **Revolved Cut**  on the Features toolbar.

Step 4. In the Cut-Revolve Property Manager set:

under Axis of Revolution 
click **line drawn across Fuselage edges**, **Fig. 27**
under Direction1, **Fig. 26**

Direction Angle  90°

click **Reverse Direction**  and click OK .



Fig. 26

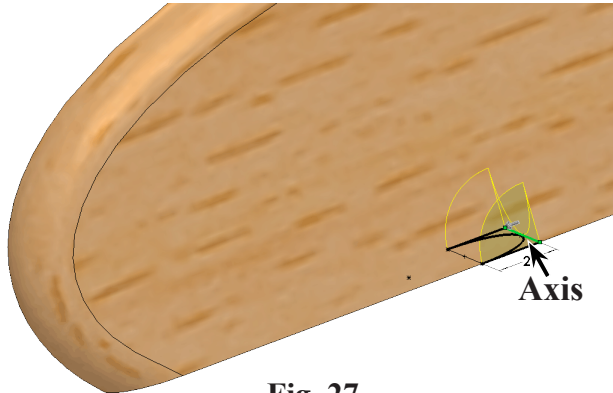

Fig. 27

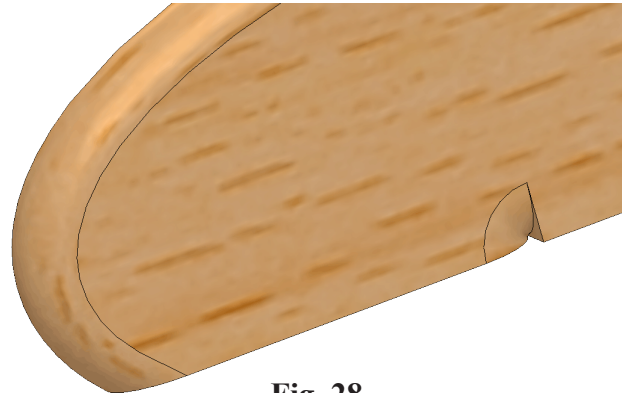



Fig. 28

G. Sweep Cut.

Step 1. Click the **flat face remaining on the Fuselage after the Cut Revolve** and click **Sketch**  on the Content menu, **Fig. 29**.

Step 2. With the Face still selected, click **Convert**

Entities  on the Sketch toolbar.

Click OK  in Convert Entities Property Manager, **Fig. 30** and **Fig. 31**.

Step 3. Click **Exit Sketch**

 on the Sketch toolbar.

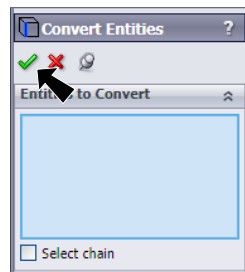

Fig. 30

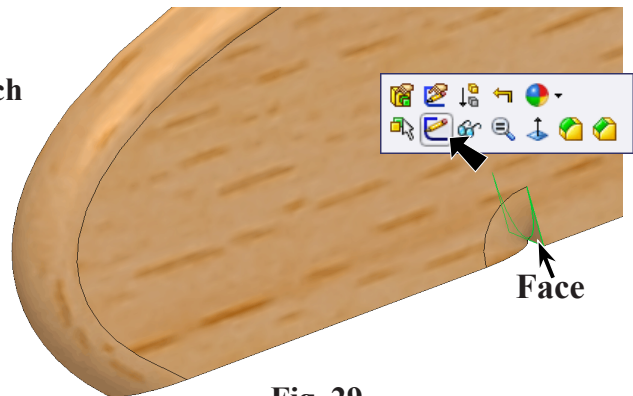

Fig. 29

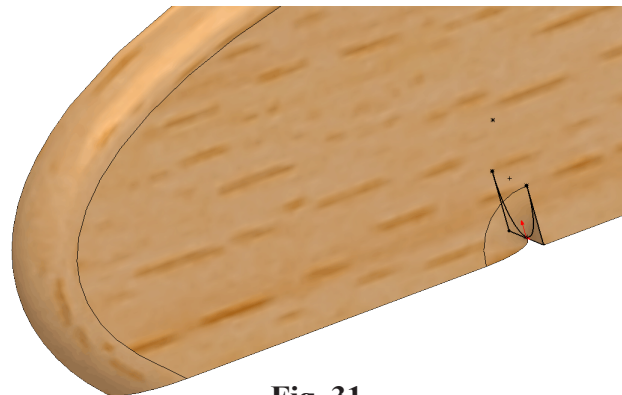



Fig. 31

Step 4. Click **Right Plane**  in the Feature Manager and click **Sketch**  from the Content toolbar, **Fig. 32**.

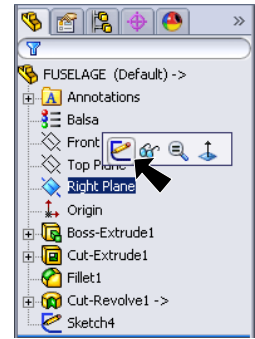

Fig. 32

Step 5. Click **Zoom to Fit**  (F) on the View toolbar.

Step 6. Click **Convert Entities**  on the Sketch toolbar.

Step 7. In the Convert Entities Property Manager:
click the **two edges along bottom of Fuselage**, **Fig. 33**

click OK  twice, **Fig. 34**, **Fig. 35** and **Fig. 36**.

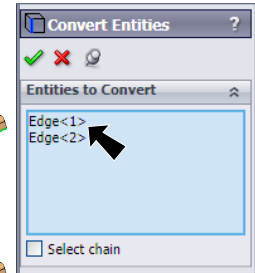



Fig. 34

Step 8. Click **Exit Sketch**  on the Sketch toolbar.

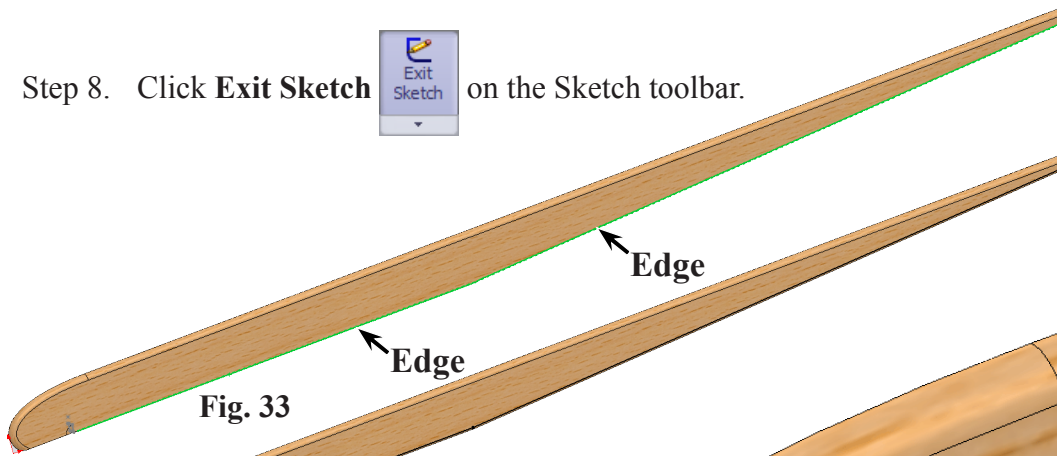

Fig. 33



Fig. 35

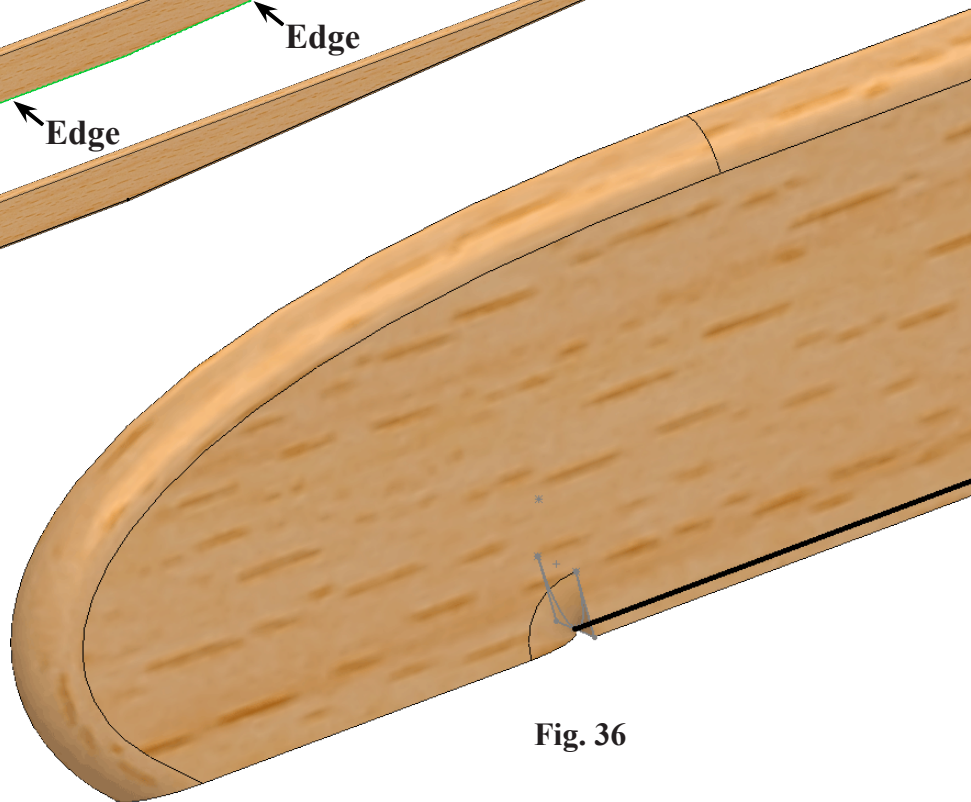

Fig. 36

Step 9. **Ctrl click both Sketches** in the Feature Manager to select both, **Fig. 37**.

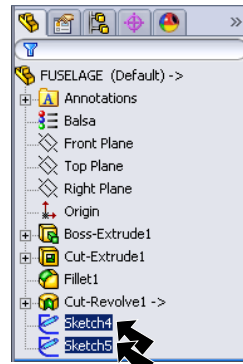



Fig. 37



Step 10. Click **Features**  on the Command Manager toolbar.

Step 11. Click **Swept Cut**  on the Features toolbar.



Fig. 38

Step 12. In the Cut Swept Property Manager:

Profile  and **Path**  were preselected, **Fig. 38**. Click **OK** .

Step 13. Save. Use **Ctrl-S**.

Step 14. Close the Fuselage part file. Use File Menu > Close.

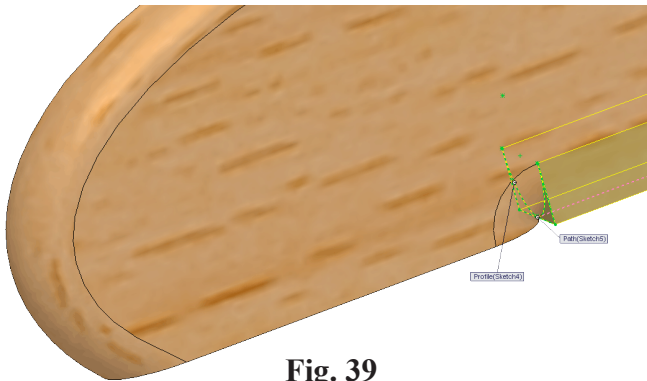

Fig. 39

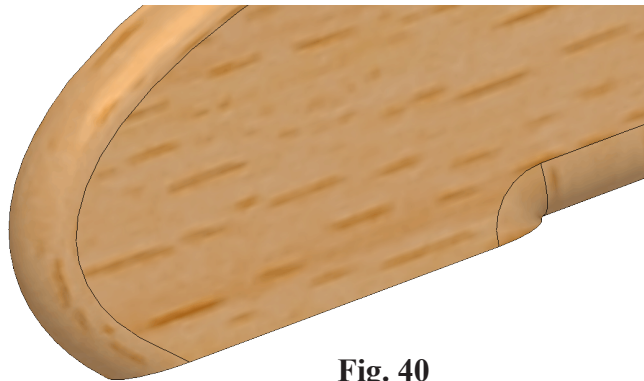

Fig. 40

H. Insert Wing Inboard.

Step 1. Back in the Assembly file, click **Trimetric**  on the Standard Views toolbar.

Step 2. Click **Insert Components**  on the Assembly toolbar.

Step 3. Click **Browse** in the Property Manager **Fig. 41**.

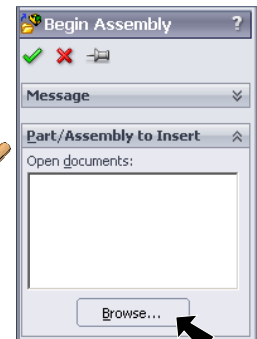

Fig. 41

Step 4. Select **Wing Inboard** file and click Open.

Step 5. Place Wing Inboard as positioned in **Fig. 42**.

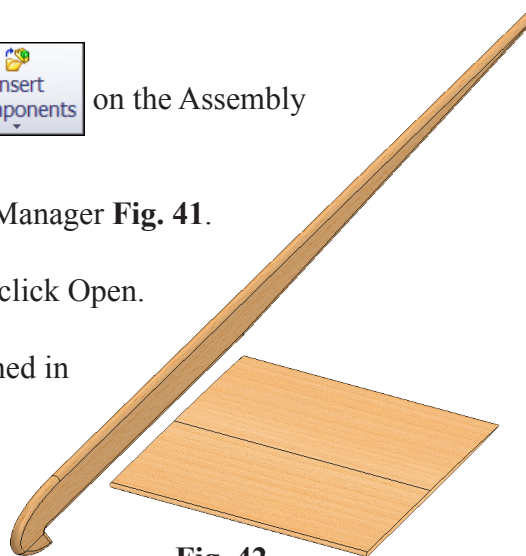

Fig. 42

I. Mate: Wing Inboard.

Step 1. Click **Mate**  on the Assembly toolbar.

Step 2. Click **side face of Fuselage**, **Fig. 43**.

Step 3. Rotate view to view **root of H Stab (inside end)** as shown in **Fig. 44**. Hold down middle mouse button (wheel) and drag.

Step 4. Click **root face of H Stab**, **Fig. 44**. Be sure to select the face. Zoom in if necessary.

Step 5. Click Add/Finish Mate  in Mate pop-up toolbar to add a **Coincident** mate.

Step 6. Click **Trimetric**  on the Standard Views toolbar.



Step 7. Zoom in on **front of Fuselage and leading edge of Wing root**, **Fig. 45**. To zoom, hold down **Shift** key and drag middle mouse button (wheel). To pan, hold down **Ctrl** key and drag middle mouse button (wheel).

Step 8. Click **edge of Fuselage fillet** and click **top front vertex of Wing root**, **Fig. 46**.

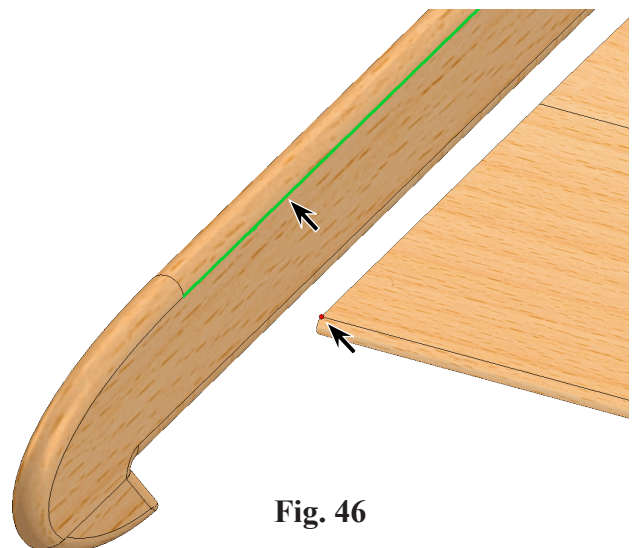
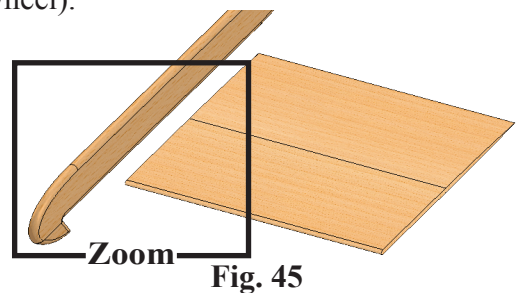
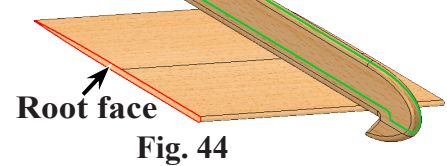
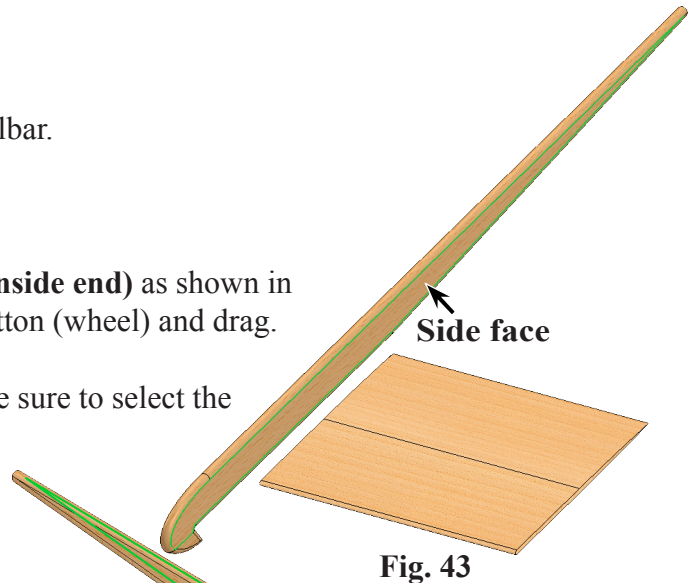
Step 9. Click Add/Finish Mate  to add a **Coincident** mate.





Step 10. Click **edge of Fuselage fillet** and **top edge Wing root**, **Fig. 46**.

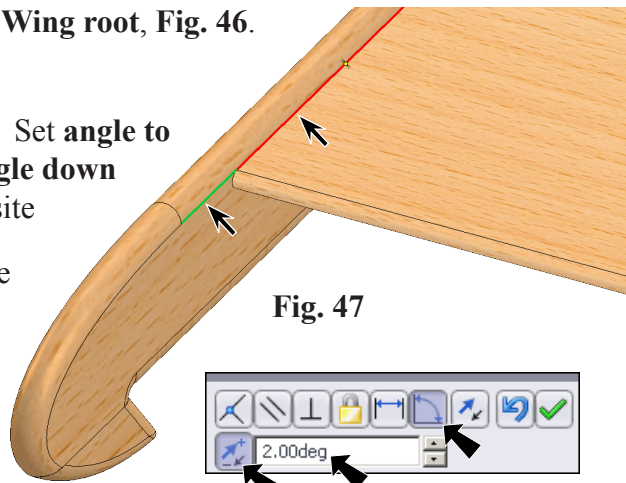

Step 11. Click **Angle**  in Mate pop-up, **Fig. 48**. Set **angle to 2** and press **ENTER**. The Wing should **angle down in the rear**, **Fig. 49**. If positioned in opposite direction, click **Flip Dimension**  in the Mate pop-up, **Fig. 48**. Click Add/Finish Mate  to add the **Angle** mate. This is the **Angle of Attack**.

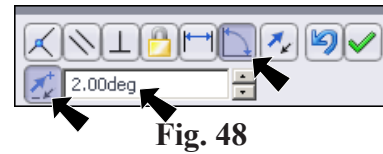



Step 12. Click **top front vertex of Wing root**, **Fig. 49**.

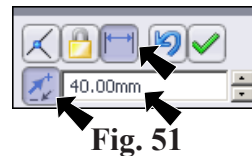
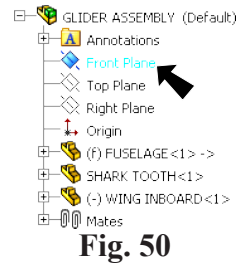
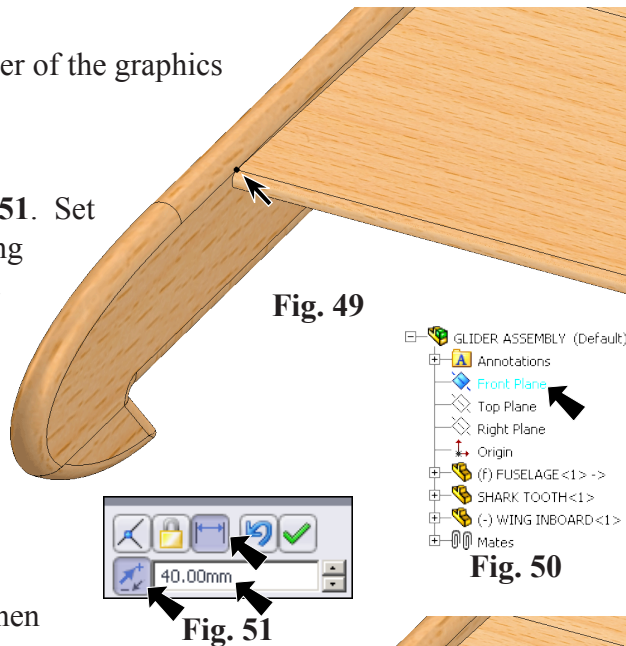

Step 13. Expand the Design Tree in the top left corner of the graphics area click **Front Plane** , **Fig. 50**.

Step 14. Click **Distance**  in Mate pop-up, **Fig. 51**. Set **distance to 40** and press **ENTER**. The Wing Inboard should be positioned 40 from front of Fuselage, **Fig. 52**. If positioned in opposite direction, click **Flip Dimension**  in the Mate pop-up, **Fig. 51**. Click Add/Finish Mate  to add Distance mate.



Step 15. Click **OK**  in the Property Manager when done.

Step 16. Save. Use **Ctrl-S**.

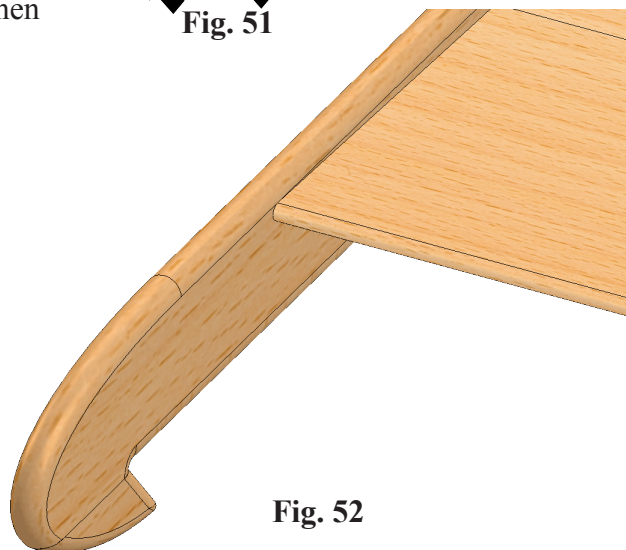

J. Insert Wing Outboard.

Step 1. Click **Trimetric**  on the Standard Views toolbar.

Step 2. Click **Insert Components**  on the Assembly toolbar.

Step 3. Open **Wing Outboard** file and place as positioned in **Fig. 53**.

K. Mate: Wing Outboard.

Step 1. Zoom in on **Wing Inboard tip and Wing Outboard root edge**, **Fig. 53**. To **zoom**, hold down **Shift** key and drag middle mouse button (wheel). To **pan**, hold down **Ctrl** key and drag middle mouse button (wheel).

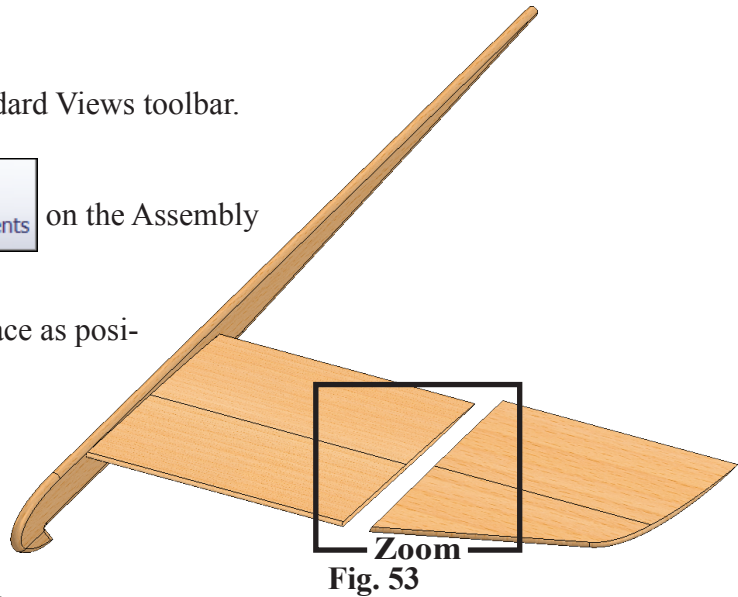

Step 2. Click **Mate**  on the Assembly toolbar.

Step 3. Click **tip (end) face of Wing Inboard**, **Fig. 54**.

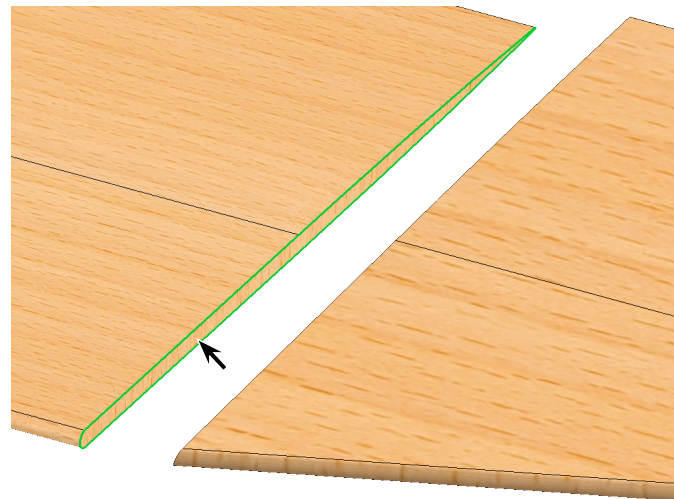

Step 4. Rotate view to view **root of Wing Outboard (inside face)** as shown in **Fig. 55**. Hold down middle mouse button (wheel) and drag.

Step 5. Click **root face of Wing Outboard**, **Fig. 55**.

Step 6. Click **Add/Finish Mate**  in Mate pop-up toolbar to add a **Coincident** mate.

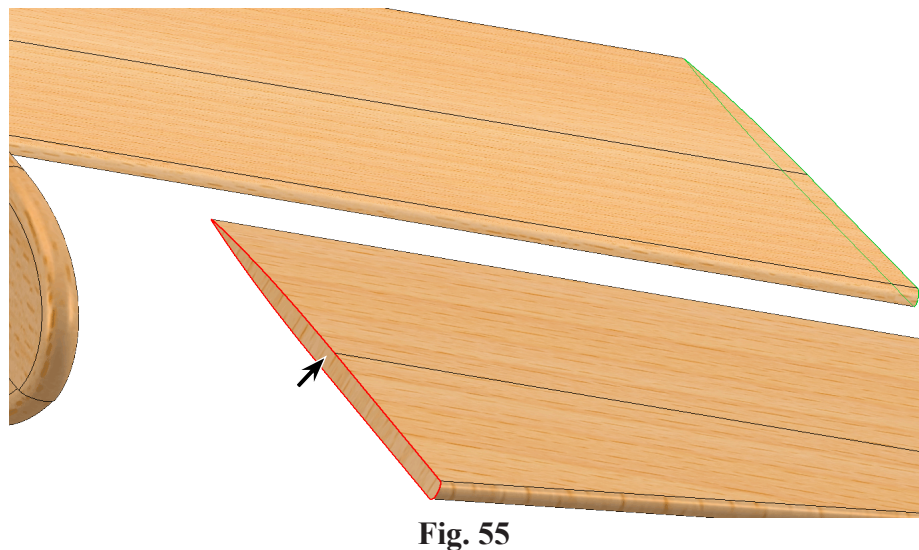

Step 7. Click **Previous View**  on the Standard Views toolbar. (**Ctrl-Shift-Z**)

Step 8. Click **top edge of Wing Inboard tip** and **edge top of Wing Outboard root**, **Fig. 56**.

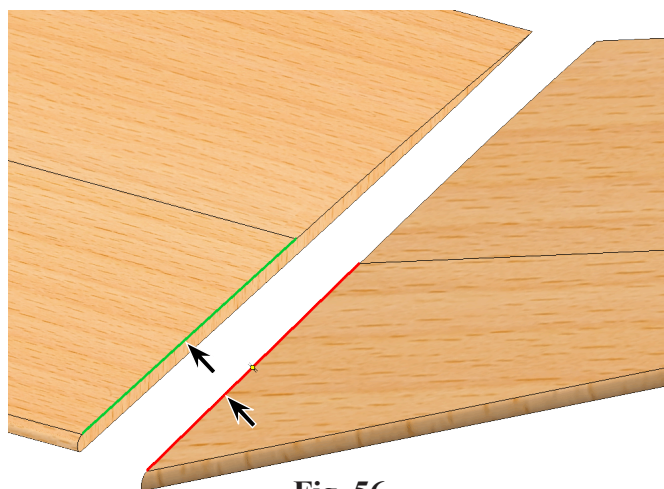



Fig. 56

Step 9. Click Add/Finish Mate  to add a **Coincident** mate.

Step 10. Click **top vertex of Wing Inboard root** and **top vertex of Wing Outboard**, **Fig. 57**.

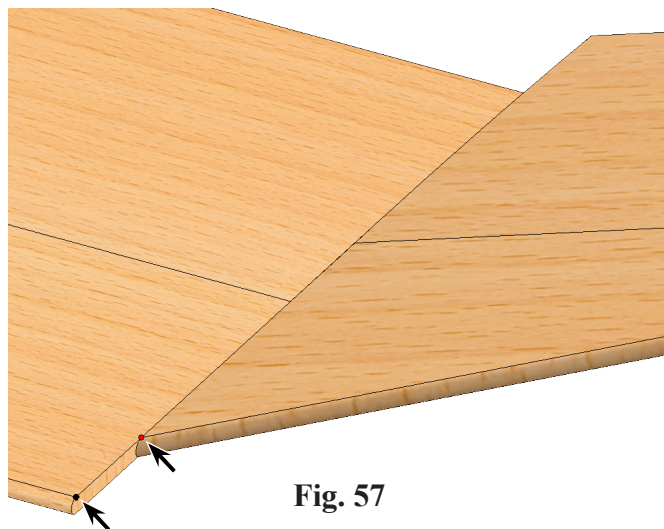



Fig. 57

Step 11. Click Add/Finish Mate  to add a **Coincident** mate, **Fig. 58**.

Step 12. Click OK  in the Property Manager when done.

Step 13. Save. Use **Ctrl-S**.

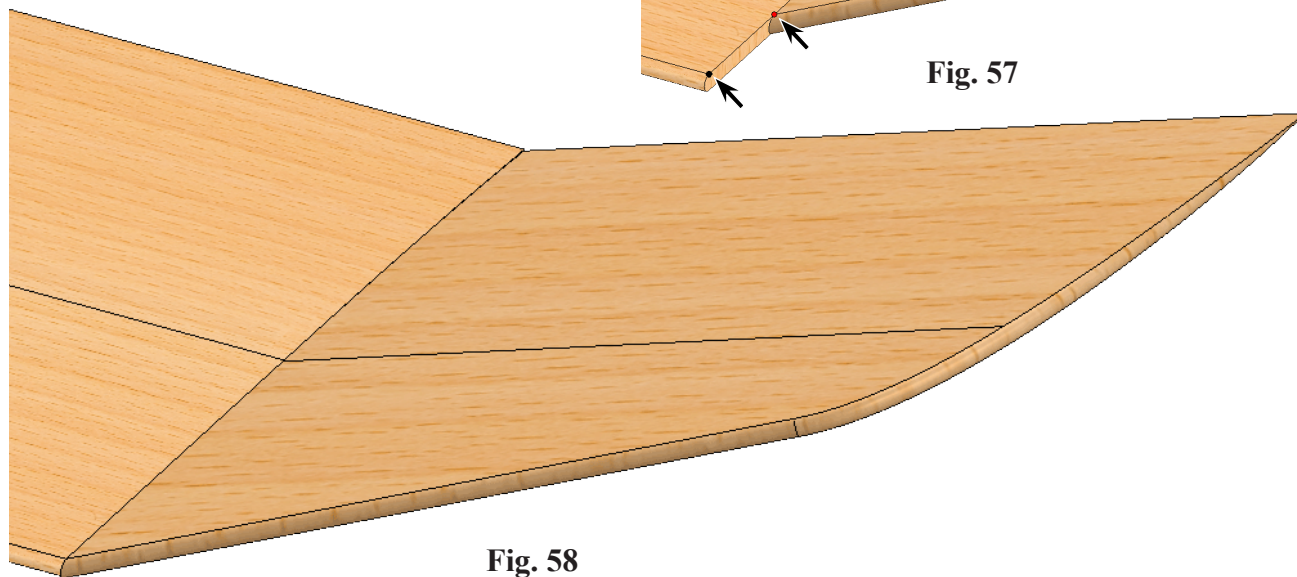



Fig. 58

L. Insert H Stab.

Step 1. Click **Trimetric**  on the Standard Views toolbar.

Step 2. Click **Insert Components**  on the Assembly toolbar.

Step 3. Click **Browse** in the Property Manager.

Step 4. Select **H Stab** and click Open.

Step 5. Place H Stab as positioned in **Fig. 59**.

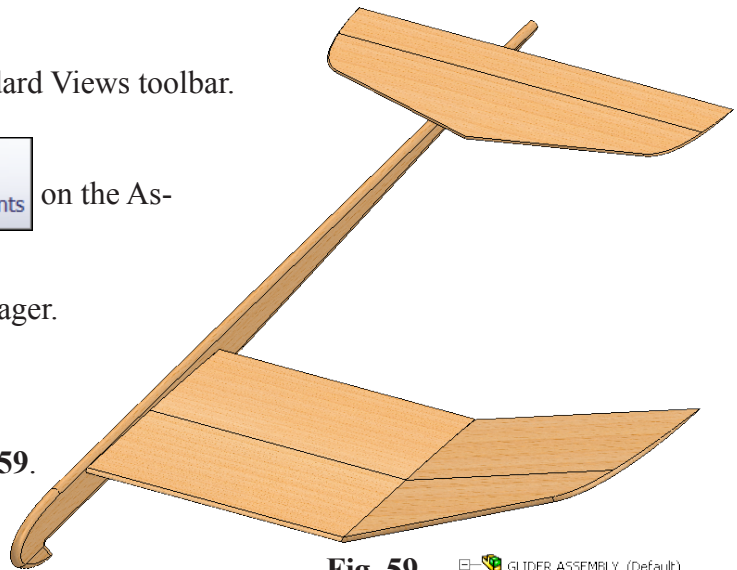



Fig. 59

M. Mate: H Stab.

Step 1. Click **Mate**  on the Assembly toolbar.

Step 2. Expand the Design Tree in the top left corner of the graphics area and click **Right Plane** , **Fig. 60**.

Step 3. Expand **H STAB** and expand **Cut-Extrude-1**. **Right click Sketch2** and **Show**  on the Content menu, **Fig. 60**.

Step 4. Click the **Centerline of the H Stab** in the graphics area, **Fig. 61**.

Step 5. Click **Add/Finish Mate**  in Mate pop-up toolbar to add a **Coincident** mate.

Step 6. **Right click Sketch2** in graphics area and click **Hide**  on the Content menu, **Fig. 62**.

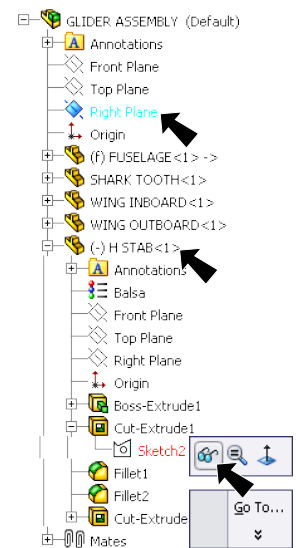

Fig. 60

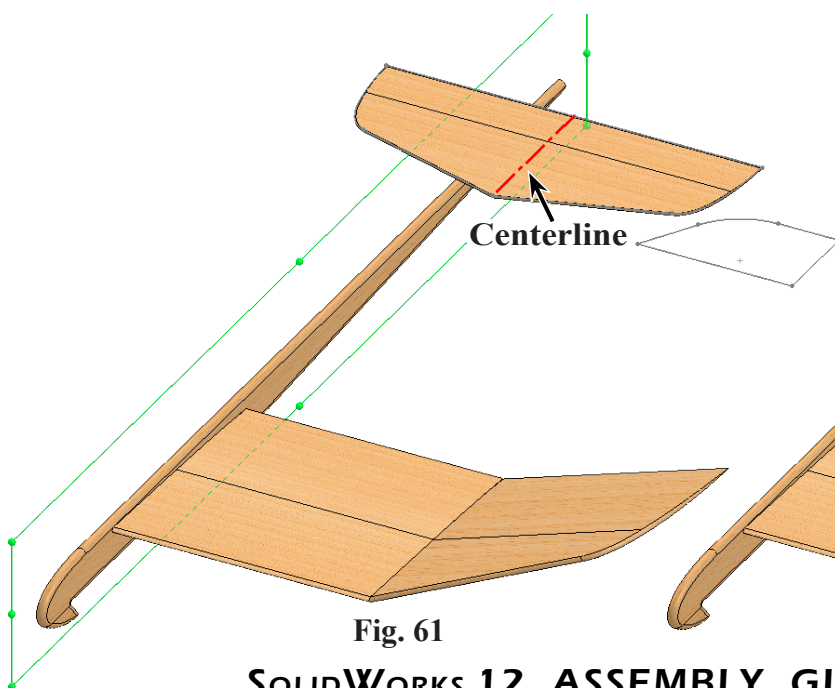

Fig. 61

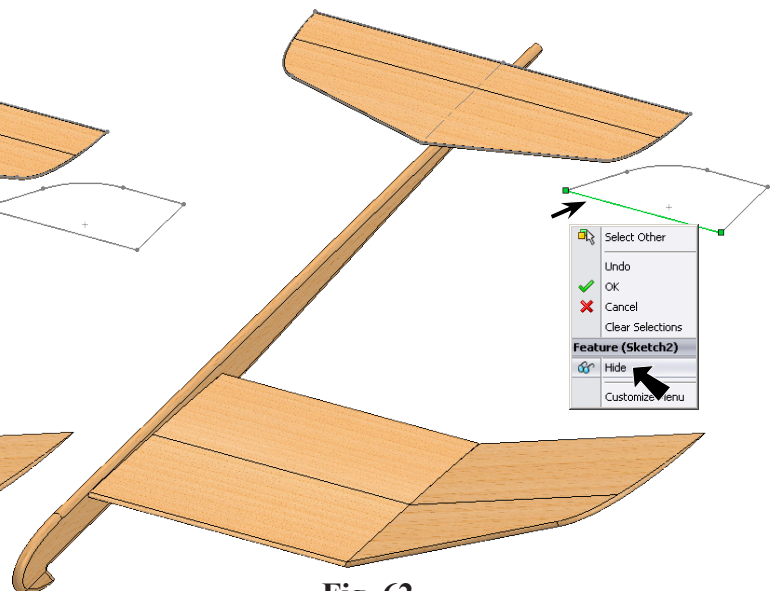



Fig. 62

Step 7. Click **Right**  on the View toolbar. (Ctrl-4)

Step 8. Zoom in around **rear of Fuselage**. To **zoom**, hold down **Shift** key and drag with middle mouse button (wheel). To **pan**, hold down **Ctrl** key and drag with middle mouse button (wheel).

Step 9. Click **Top Plane** , **Fig. 63**.

Step 10. Expand **H STAB** and click **Top Plane** , **Fig. 63**.

Step 11. Click **Distance**  in Mate pop-up, **Fig. 64**. Set distance to **13** and press ENTER. The H Stab should sit down into the Fuselage, **Fig. 65**. If positioned in opposite direction, click **Flip Dimension**



 in the Mate pop-up, **Fig. 64**. Click Add/Finish Mate  to add Distance mate.



Fig. 64

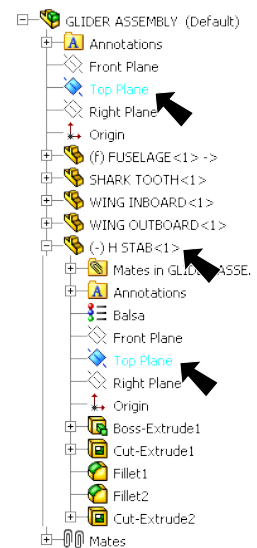





Fig. 63

Fig. 65

Step 12. Click **Front Plane** , **Fig. 66**.

Step 13. Expand **H STAB** and click **Front Plane** , **Fig. 66**.

Step 14. Click **Distance**  in Mate pop-up, **Fig. 67**. Set distance to **249** and press ENTER. The H Stab should align with rear of Fuselage, **Fig. 68**. If positioned in opposite direction, click **Flip Dimension**  in the Mate pop-up, **Fig. 67**. Click Add/Finish Mate  to add Distance mate.

Step 15. Click OK  in the Property Manager.

Step 16. Save. Use **Ctrl-S**.



Fig. 67



Fig. 68

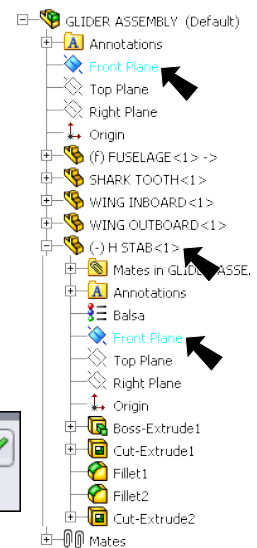
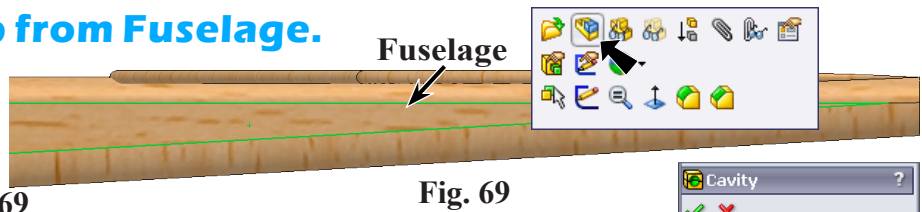

Fig. 66

N. Subtract H Stab from Fuselage.

Step 1. Click the **Fuselage** and click **Edit**

Part  on the Content menu, **Fig. 69**.



Step 2. Click Insert Menu > Features > Cavity.

Step 3. In the Cavity Property Manager set:
under Design Components
in the Design Component box, **Fig. 70**
click the **H Stab**, **Fig. 71**

click OK .

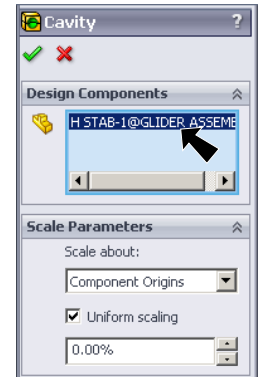
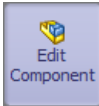

Fig. 70

Step 4. Click **Edit Com-**

ponent  on the Features toolbar to turn off edit component and return to the assembly file.

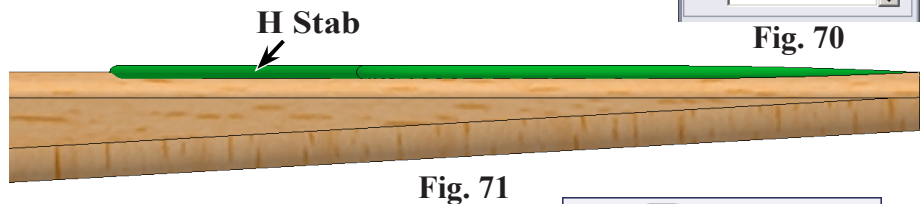

Fig. 71

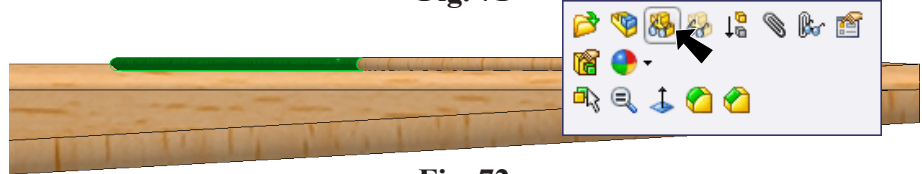



Fig. 72

Step 5. Hide the H Stab to see cavity. To hide, click **H Stab** in graphics area
and **Hide Components**  from the Content menu, **Fig. 72** and **Fig. 73**.

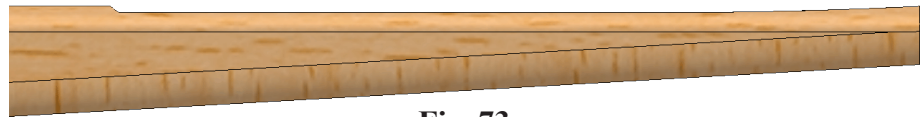

Fig. 73

Step 6. Click **H Stab** in Feature Manager and click **Show Components**

 on the Content menu, **Fig. 74**.

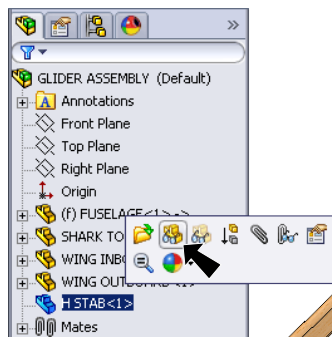



Fig. 74

Step 7. Save. Use **Ctrl-S**.

O. Insert V Stab.

Step 1. Click **Trimetric**  on the Standard Views toolbar.

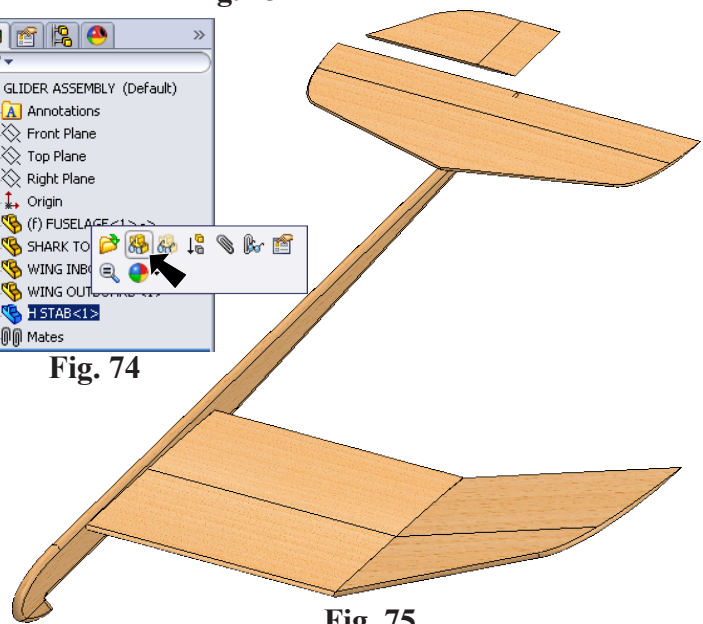



Fig. 75

Step 2. Click **Insert Components**  on the Assembly toolbar.

Step 3. Click **Browse** and place V Stab as positioned in **Fig. 75**.

P. Mate: V Stab.

Step 1. Click **Mate**  on the Assembly toolbar.

Step 2. Expand the Design Tree and click **Right Plane** , **Fig. 76**.

Step 3. Expand **V STAB** and click **Top Plane** , **Fig. 76**.

Step 4. Click **Flip Mate Alignment**  in Mate pop-up, **Fig. 77**. The V Stab should be positioned as shown in **Fig. 78**.

Click Add/Finish Mate  to add a **Coincident** mate.

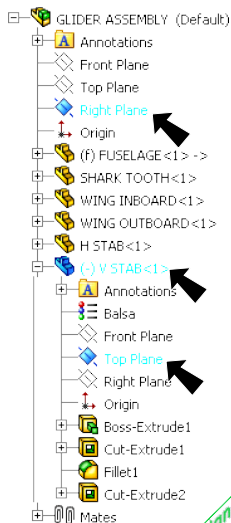

Fig. 76



Fig. 77

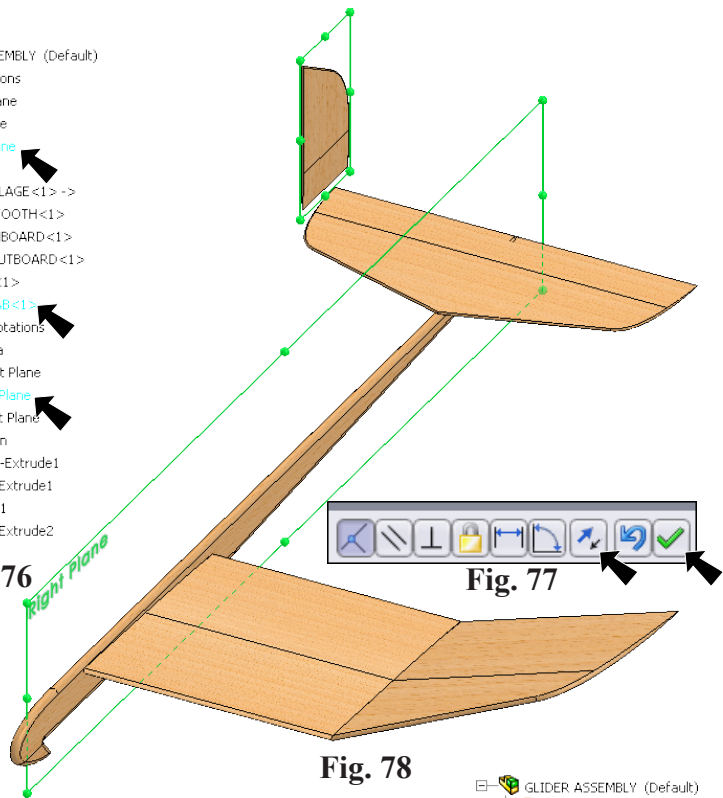



Fig. 78

Step 5. Click **Right**  on the View toolbar. (**Ctrl-4**)

Step 6. Expand the Design Tree and click **Top Plane** , **Fig. 79**.

Step 7. Expand **V STAB** and click **Front Plane** , **Fig. 79**.



Step 8. Click **Distance**  in Mate pop-up, **Fig. 80**. Set distance to **13** and press **ENTER**. The root edge of H Stab should align with Fuselage,

Fig. 81. If positioned in opposite direction, click **Flip Dimension**  in the Mate pop-up, **Fig. 80**. Click Add/Finish Mate  to add Distance mate.

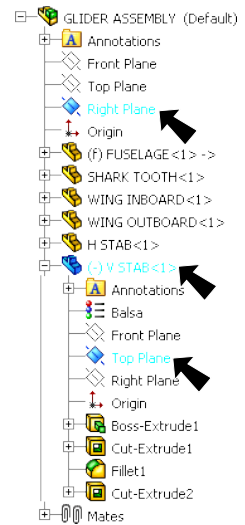

Fig. 79



Fig. 80

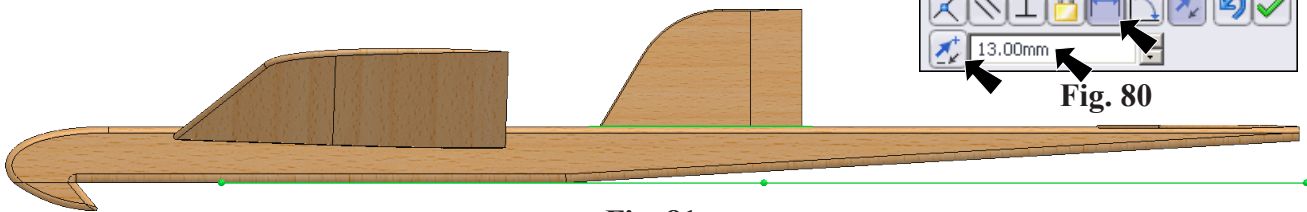





Fig. 81

Step 9. Click **Front Plane** , **Fig. 82**.

Step 10. Expand **V STAB** and click **Right Plane** , **Fig. 82**.

Step 11. Click **Distance**  in Mate pop-up, **Fig. 83**. Set **distance to 300** and press ENTER. The trailing edge of V Stab should align with rear edge of Fuselage, **Fig. 84**. If positioned in opposite direction, click **Flip Dimension**  in the Mate pop-up. Click Add/Finish Mate  to add Distance mate.

Step 12. Click OK  in the Property Manager.



Fig. 83

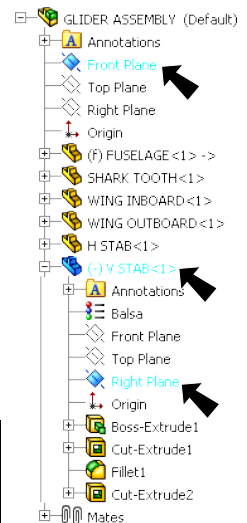

Fig. 82

Step 13. Save. Use **Ctrl-S**.

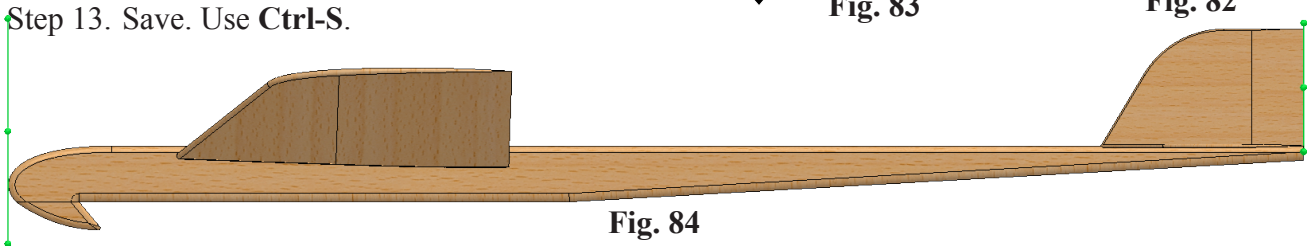



Fig. 84

Q. Subtract H Stab from V Stab.

Step 1. Zoom in around **V Stab** and rear of **Fuselage**. To **zoom**, hold down **Shift** key and drag with middle mouse button (wheel). To **pan**, hold down **Ctrl** key and drag with middle mouse button (wheel).

Step 2. Click the **V Stab** and click **Edit Part**  on the Content menu, **Fig. 85**.

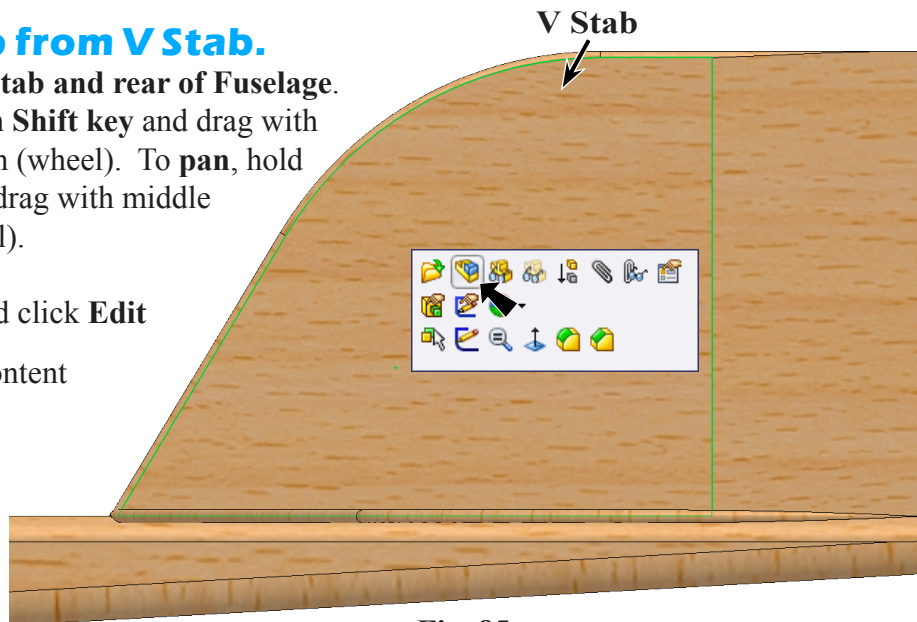



Fig. 85

Step 3. Click Insert Menu > Features > Cavity.

Step 4. In the Cavity Property Manager set:
under Design Components
in the Design Component box, **Fig. 86**
click the **H Stab**, **Fig. 87**
click OK .

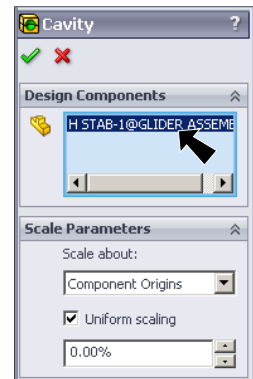

Fig. 86

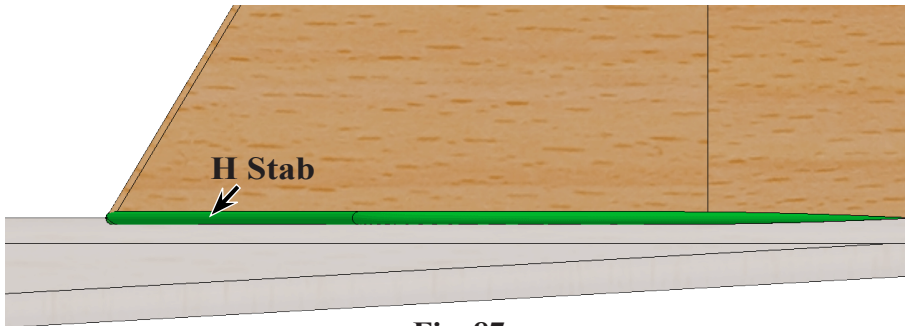

Fig. 87

Step 5. In the Bodies to Keep dialog box set:
under Bodies, **Fig. 87**
select **Selected bodies**
check **Body 1**
click OK.

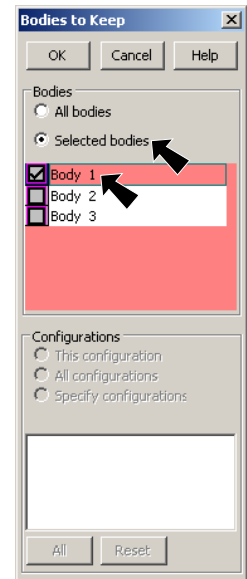

Fig. 88

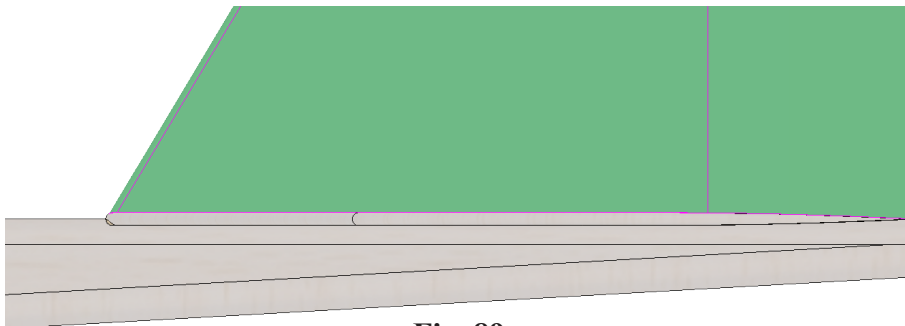

Fig. 89

Step 6. Click **Edit Component**  on the Features toolbar to turn off edit component and return to the assembly file.

Step 7. Save. Use **Ctrl-S**.



Fig. 90

R. Confirm Subtraction.

Step 1. Isolate V Stab to confirm cavity. To Isolate, **right click V Stab** and click **Isolate** in the menu, **Fig. 91** and **Fig. 92**.

Step 2. Click **Exit Isolate** button, **Fig. 93**.

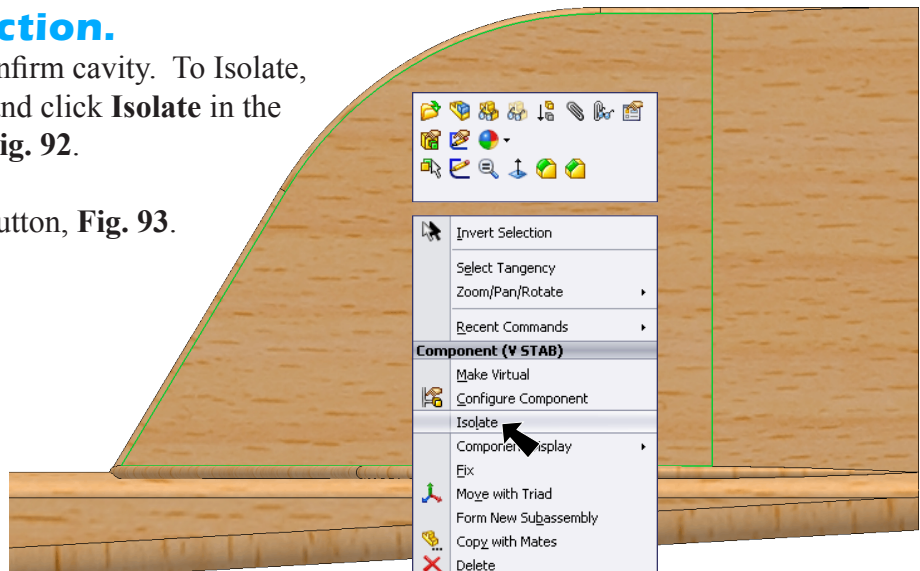

Fig. 91





Fig. 93



Fig. 92

S. Mirror Wings and H Stab.

Step 1. Click **Trimetric**  on the Standard Views toolbar.

Step 2. **Ctrl click** the **Right Plane** , **WING INBOARD** and **WING OUTBOARD** in the Feature Manager to select all three, **Fig. 94**. To **Ctrl click**, click **Right Plane** , hold down the **Ctrl** key and click both **WINGS**.

Step 3. Click **Insert Menu > Mirror Components**.

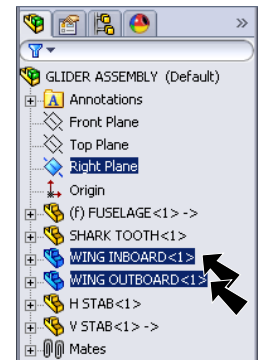





Fig. 94

Step 4. In the Mirror Components Property Manager:

- click Next , **Fig. 95**
- under Orient Components
- click the **Wing Outboard**, **Fig. 97**
- click **Create opposite hand version** , **Fig. 97**
- click OK .

Step 5. Save.
Use **Ctrl-S**.

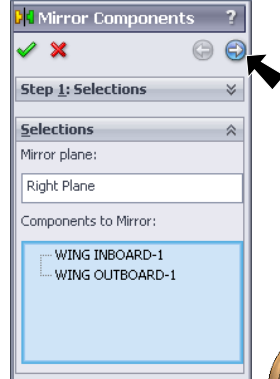

Fig. 95

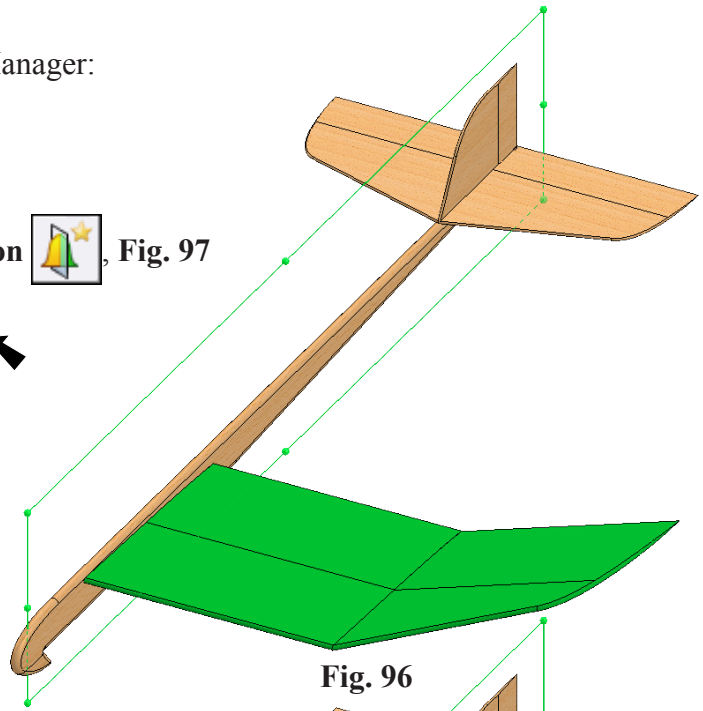

Fig. 96

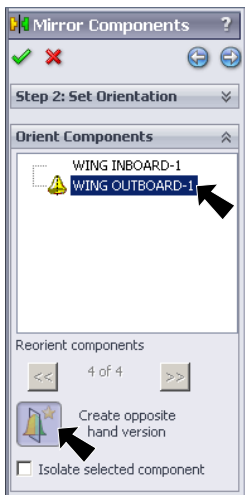

Fig. 97

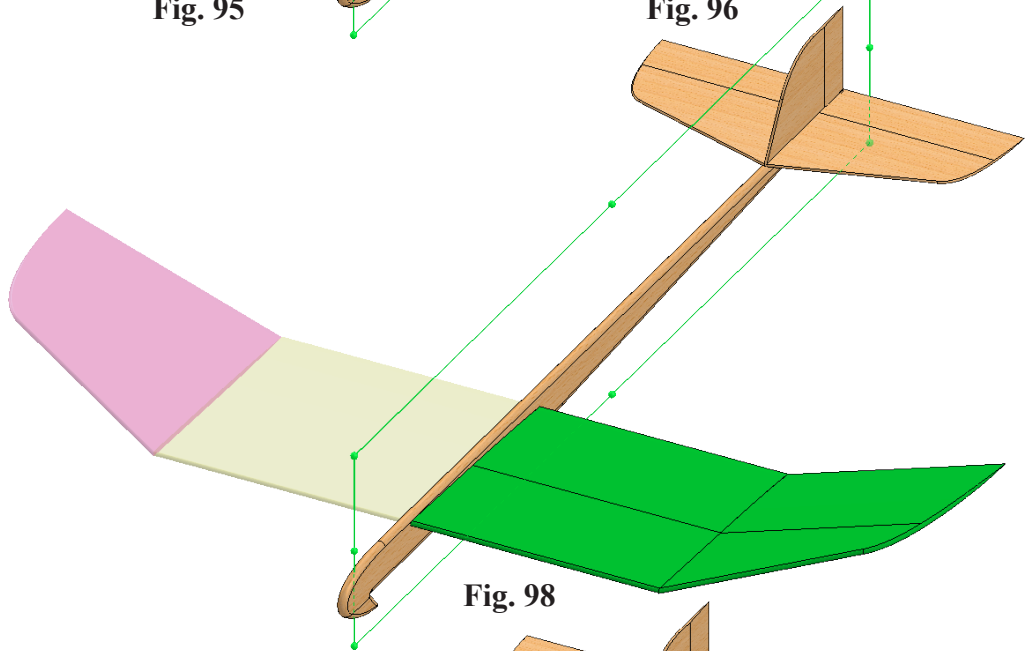

Fig. 98

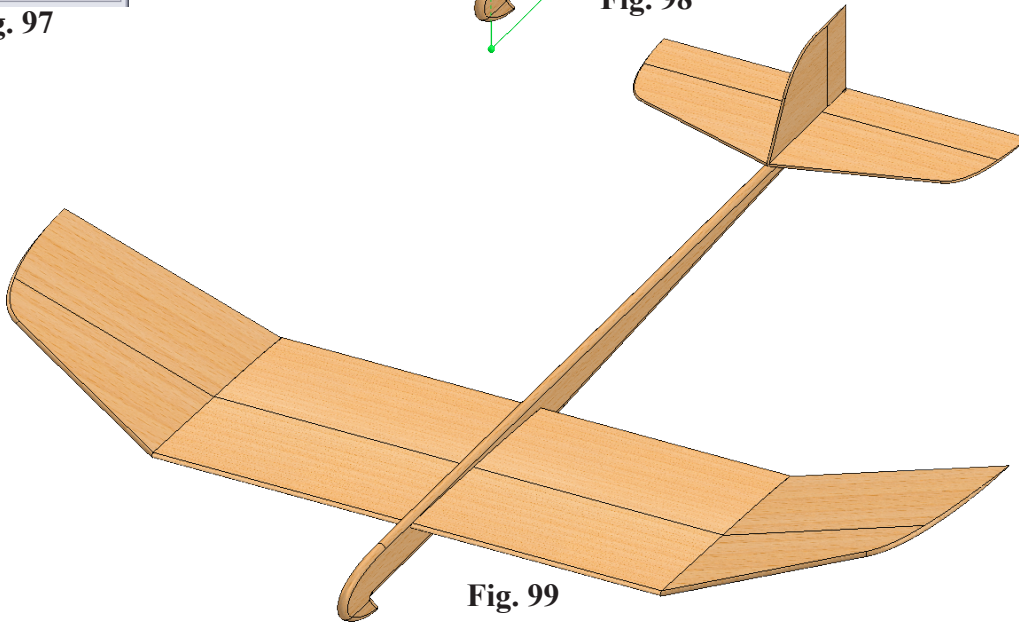

Fig. 99