

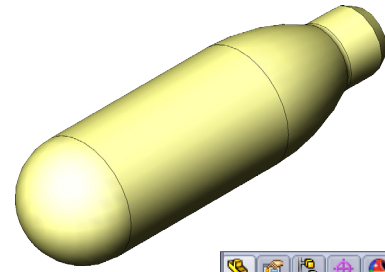

Rail Car E Cartridge



A. Sketch Lines.

Step 1. Click File Menu > New, click **Part Metric** and OK.

Step 2. Click **Right Plane**  in the Feature Manager and click **Sketch**  from the Content toolbar, **Fig. 1**.

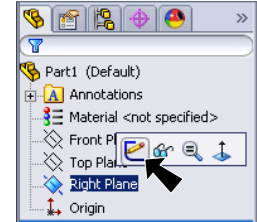

Fig. 1

Step 3. Click **Line**  (L) on the Sketch toolbar.

Step 4. Draw lines as shown in **Fig. 2**. Start at the Origin .

Use the inferencing line, the dotted line that appears when you draw the lines.



Fig. 2

Step 5. Click **Smart Dimension**  (S) on the Sketch toolbar.

Step 6. Add the dimensions as shown in **Fig. 3**. Arrange the dimensions as **Fig. 3**.

Step 7. Click Zoom to Fit  (F) on the View toolbar.

B. Save as "CARTRIDGE".

Step 1. Click File Menu > Save As.

Step 2. Key-in **CARTRIDGE** for the filename and press ENTER.

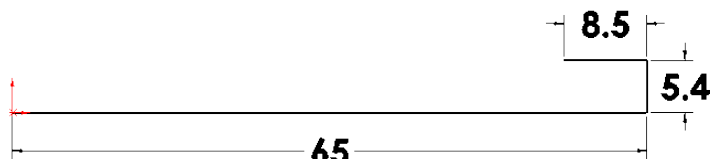



Fig. 3

C. Centerpoint Arc.

Step 1. Click **Centerpoint Arc**  (S) in the **Arc flyout**  on the Sketch toolbar.

Step 2. Click the bottom horizontal line close to the Origin to place the center of the arc. Click the Origin to start the first end point, then move cursor down and around counterclockwise 270 degrees and a 90 degrees arc. Click to place the second end point, **Fig. 4**. Use the inferencing line, the dotted line that appears when you draw the arc 90 degrees.

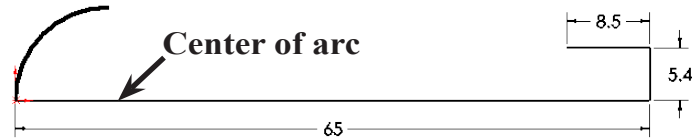

Fig. 4

Step 3. Click **Smart Dimension**  (S) on the Sketch toolbar.

Step 4. Dimension the arc radius **9.5** as shown in **Fig. 5**. To Smart dimension click the arc then move the cursor out away from the arc and click. Key-in the dimension and press ENTER. Arrange the dimension as **Fig. 5**.

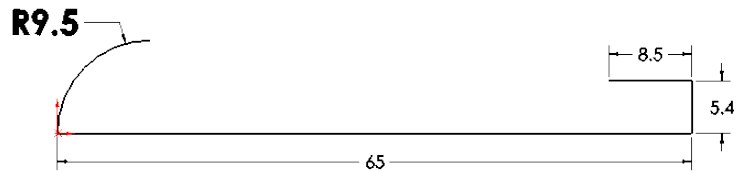

Fig. 5

D. Line.

Step 1. Click **Line**  (L) on the Sketch toolbar.

Step 2. Starting from the end of the arc, draw a horizontal line across the sketch as shown in **Fig. 6**. Keep the line away from the short horizontal line.

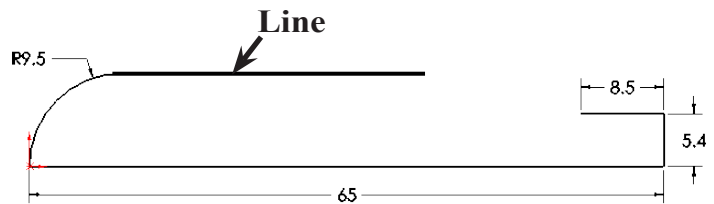



Fig. 6

Step 3. Click **Smart Dimension**  (S) on the Sketch toolbar.

Step 4. Dimension the line **31** as shown in **Fig. 7**.

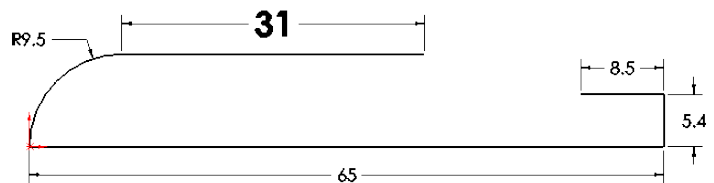

Fig. 7

Step 5. Save. Use **Ctrl-S**.

E. Tangent Arc.

Step 1. Click **Tangent Arc**  in the **Arc flyout**  on the Sketch toolbar.

Step 2. Draw an arc between Position 1 and Position 2 in **Fig. 8**.

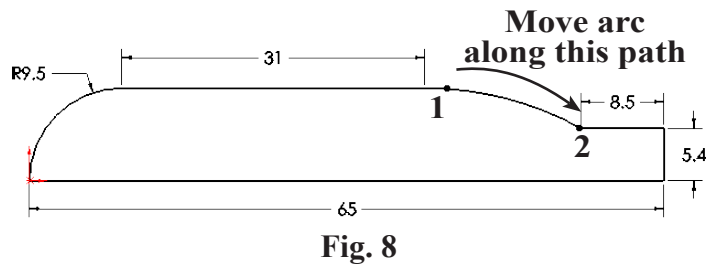

F. Sketch Fillet.

Step 1. Click **Sketch Fillet**  on the Sketch toolbar.

Step 2. In the Fillet Property Manager set,

Radius  **2, Fig. 9**

click corner shown in **Fig. 10**
click OK twice .

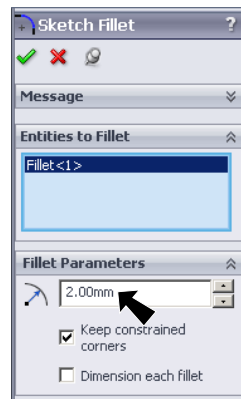

Fig. 9

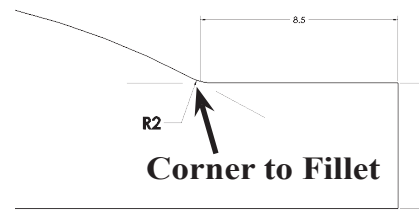
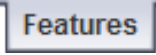



Fig. 10

G. Revolve.

Step 1. Click **Features**  on the Command Manager toolbar.

Step 2. Click **Revolved Boss/Base**  on the Features toolbar.

Step 3. In the Revolve Property Manager,

for Axis of Revolution , **Fig. 11**,
click the **bottom line of sketch**, **Fig. 12**

click OK , **Fig. 13**.

Step 4. Click **Zoom to Fit**  (F) on the View toolbar.

Step 5. Save. Use **Ctrl-S**.

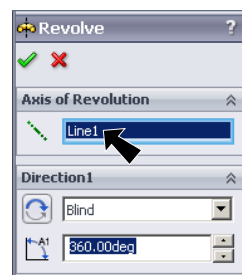

Fig. 11

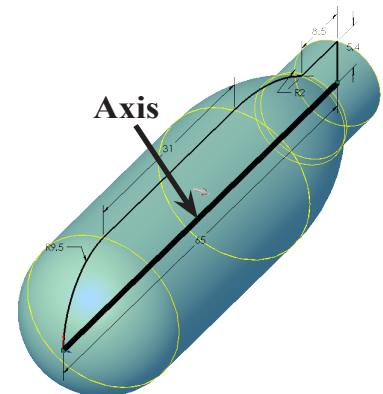

Fig. 12

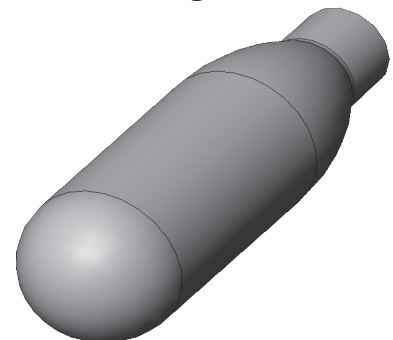

Fig. 13

H. Chamfer.

Step 1. Hold down middle mouse button (wheel) and drag to **rotate view** as shown in **Fig. 15**.

Step 2. Click **Chamfer**  on the Features toolbar.

Step 3. In the Chamfer Property Manager set:

Distance distance

Depth 1  **1**

Depth 2  **2, Fig. 14**

click the **corner edge**, **Fig. 15**

click OK , **Fig. 16**.

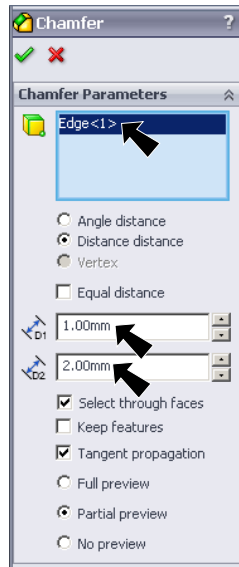

Fig. 14

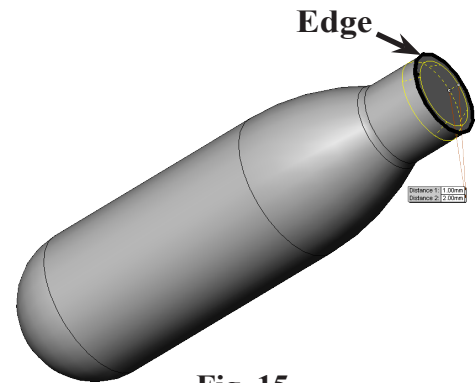

Fig. 15

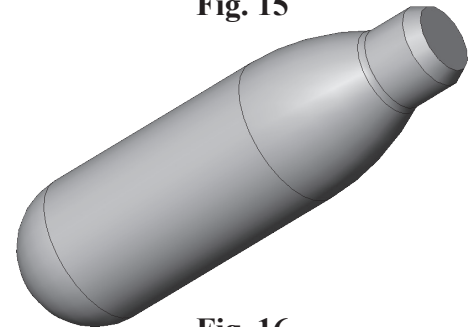



Fig. 16

Step 4. Save. Use **Ctrl-S**.

I. Shell.

Step 1. Click **Isometric**  on the Standard Views toolbar. (**Ctrl-7**)

Step 2. Click **Wireframe**  on the View toolbar.

Step 3. Click **Shell**  on the Features toolbar.

Step 4. In the Shell Property Manager set:

Distance  **1.25, Fig. 17**

click OK , **Fig. 19**.

The Shell hollows out the inside of the cartridge.

Step 5. Click **Shaded With Edges**  on the View toolbar.

Step 6. Save. Use **Ctrl-S**.

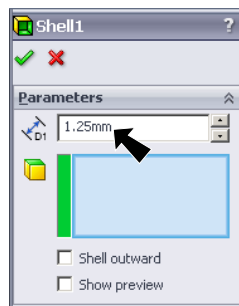

Fig. 17

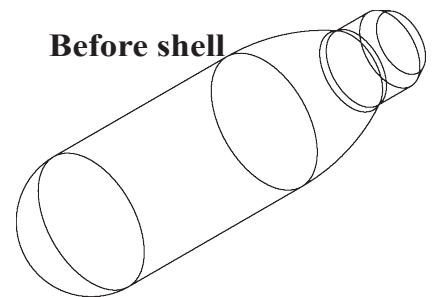

Fig. 18

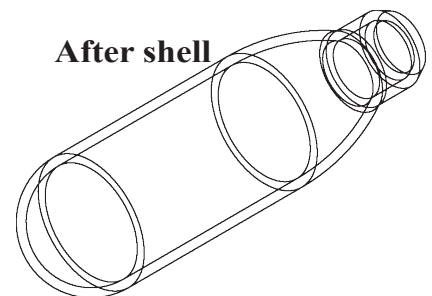



Fig. 19

J. Material Steel 304.

- Step 1. Right click **Material**  in the Feature Manager and click **Edit Material**.
- Step 2. Expand **Steel** in the material tree and select **Steel AISI 304**. Click **Apply** and **Close**.
- Step 3. Save. Use **Ctrl-S**.

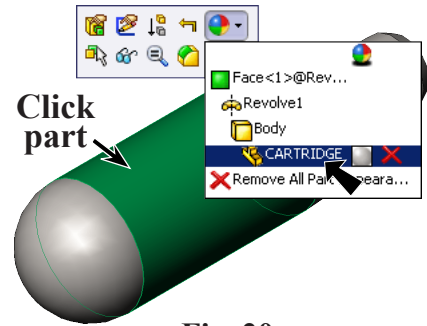





Fig. 20

K. Appearance Color.

- Step 1. Click the part, expand **Appearance Callout**  on the Content menu and click **CARTRIDGE** , Fig. 20.
- Step 2. In the Appearances Property Manager, under Color:
 - select **Shiny**, Fig. 21
 - click second **Yellow** swatch
 - click OK , Fig. 22.
- Step 3. Save. Use **Ctrl-S**.

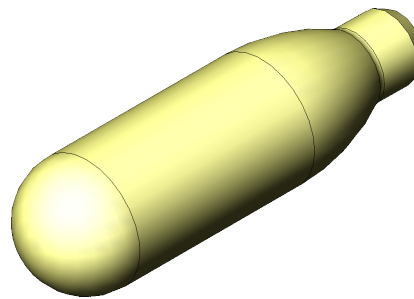

Fig. 22

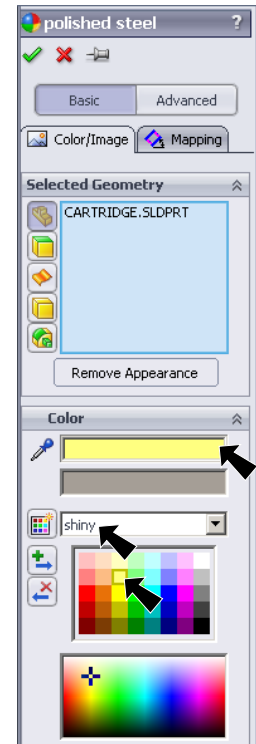
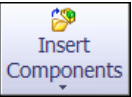

Fig. 21

L. Insert Cartridge in Assembly.

- Step 1. Click File Menu > Open. Select your ASSEMBLY file and click OK.
- Step 2. Hold down middle mouse button (wheel) and drag to **rotate view** to view the bottom and side of the cartridge hole, Fig. 23.
- Step 3. Click **Insert Components**  on the Assembly toolbar.
- Step 4. Click **Browse** in the Property Manager.
- Step 5. Select your **CARTRIDGE** file and click Open.
- Step 6. Click approximately where the cartridge is positioned in Fig. 23.

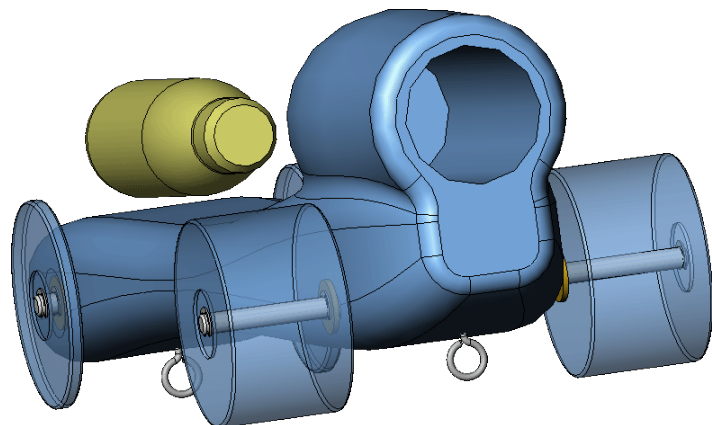

Fig. 23

M. Mate: Cartridge and Body.

Step 1. Click **Mate**  on the Assembly toolbar.

Step 2. Click **cylindrical face of cartridge** and **cylindrical face of cartridge hole**, **Fig. 24**.

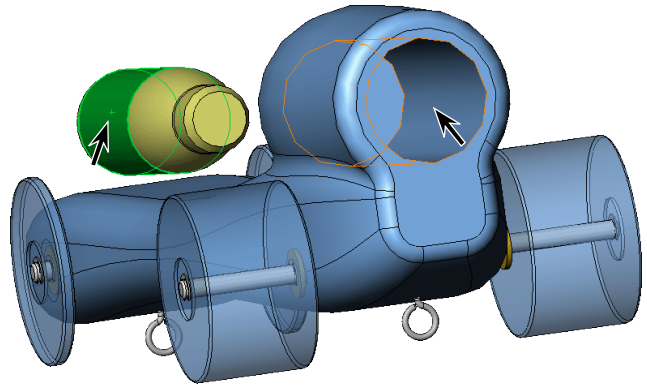



Fig. 24

Step 3. Click Add/Finish Mate  in Mate pop-up toolbar to add a **Concentric** mate.

Step 4. Click **bottom face of the cartridge hole**, **Fig. 25**.

Step 5. Rotate view to view **bottom of cartridge**, hold down middle mouse button (wheel) and drag to rotate view, **Fig. 26**.

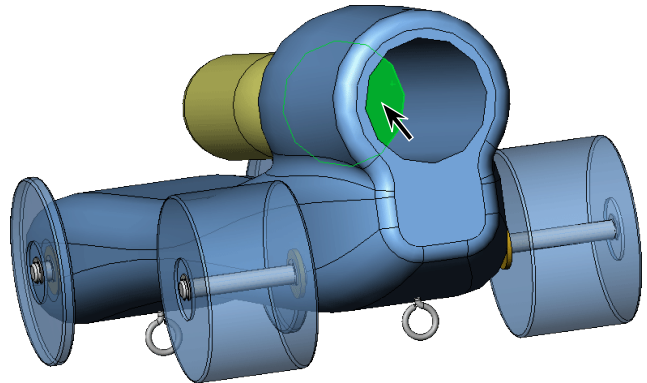



Fig. 25

Step 6. Click **bottom face of the cartridge**, **Fig. 26**.

Step 7. The cartridge should extend out the rear of the body, **Fig. 28**. If in opposite direction, click **Flip** **Mate Alignment**  in the Mate pop-up, **Fig. 27**.

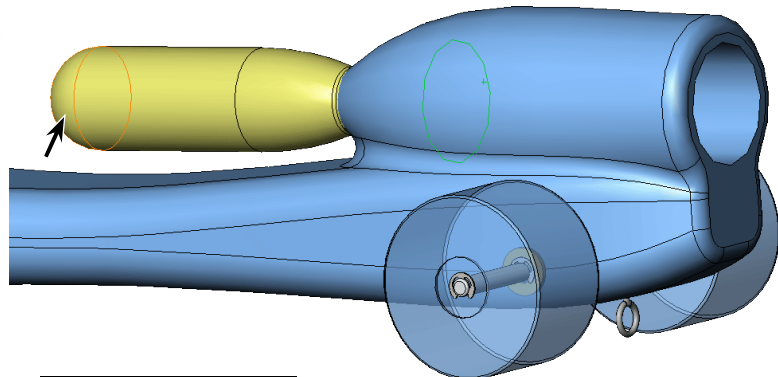

Fig. 26

Step 8. Click Add/Finish Mate  in Mate pop-up toolbar to add a **Tangent** mate.



Fig. 27

Step 9. Click OK  in the Property Manager when done.

Step 10. Save. Use **Ctrl-S**.

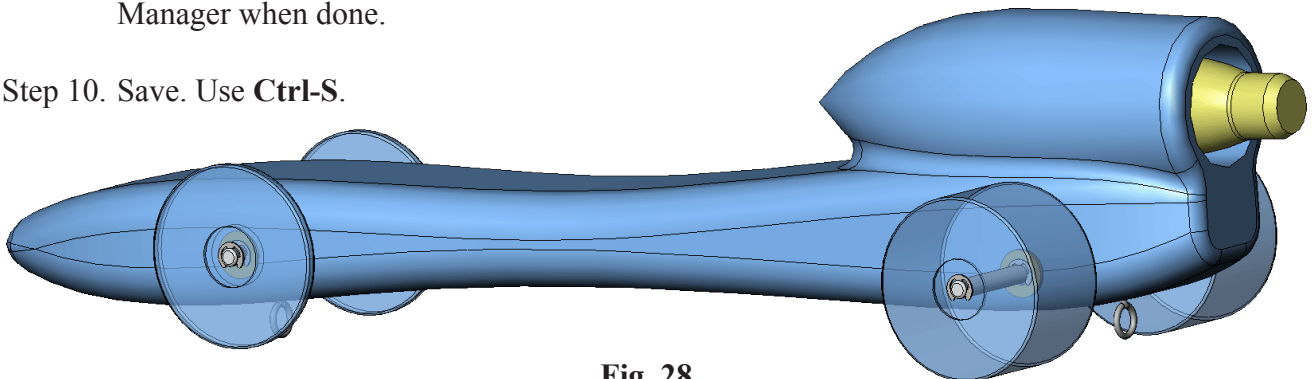

Fig. 28