

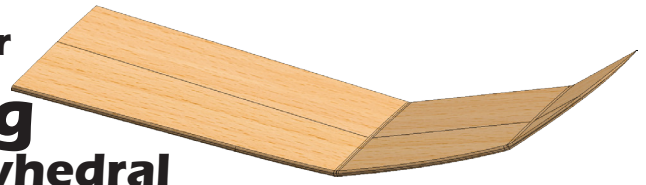

Glider Wing 6 Panel Polyhedral



A. Open and Save As "WING 6 PANEL POLY".

- Step 1. Open your WING BLANK file.
- Step 2. Click File Menu > Save As.
- Step 3. Key-in WING 6 PANEL POLY for the filename and press ENTER.

B. Sketch Wing.

- Step 1. Click the **top face** of the Wing Blank and click **Sketch**  on the Content menu, Fig. 1.

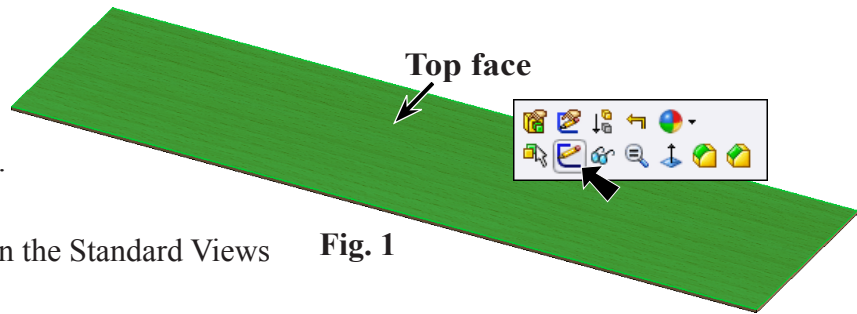

- Step 2. Click **Normal To**  on the Standard Views toolbar. (Ctrl-8)

Fig. 1

C. Lines.

- Step 1. Click **Line**  (L) on the Sketch toolbar.

- Step 2. Draw 4 lines, Fig. 2. Draw vertical centerline down Wing Blank through the Origin. Start from Midpoint  of an edge of Wing Blank. **Right click** and click End-chain from menu to restart line or use the L key to select Line tool and to end-chain.

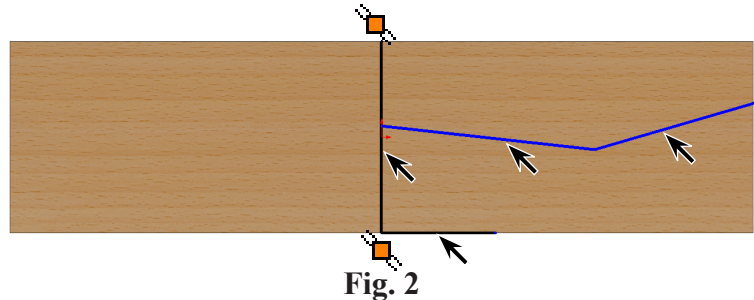

Fig. 2

- Step 3. Click **Smart Dimension**  (S) on the Sketch toolbar.

- Step 4. Add the Dimensions as shown in Fig. 3. To Smart dimension an angle, click both lines, then move the cursor between lines and click. Key-in the dimension and press ENTER. Add the other dimensions.

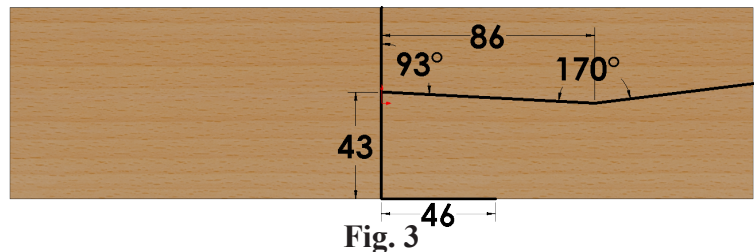

Fig. 3

- Step 5. Save. Use Ctrl-S.

D. 2 Point Spline.

Step 1. Click **Spline**  (S) on the Sketch toolbar.

Step 2. Draw a **2 Point Spline** from endpoint of angled line to endpoint of horizontal line, **Fig. 4**. Press Escape to end spline.

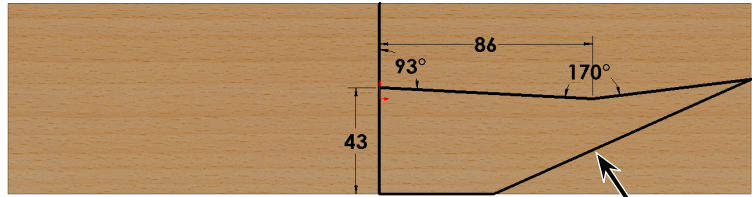

Fig. 4



Step 3. **Ctrl click line horizontal and spline** to select both. Release Ctrl key and click **Make Tangent**  on the Content menu, **Fig. 5**.



Fig. 5

Step 4. Click **Smart Dimension**  (S) on the Sketch toolbar.

Step 5. Dimension Spline Point 1 **Tangent Weighting2 113**, **Fig. 6** and **Fig. 7**. To dimension Tangent Weighting, click the **Circular Spline handle** , **Fig. 6**, then move the cursor out away from spline and click. Key-in 113 and press ENTER.

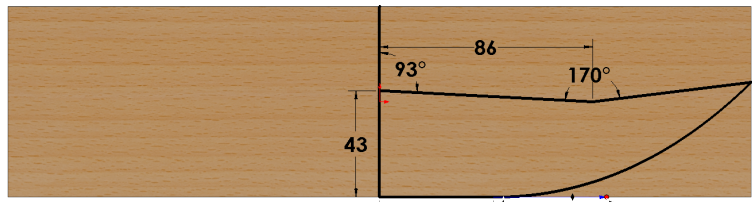



Fig. 6

Step 6. Dimension Spline Point 2 **Tangent Weighting1 145**, **Fig. 8** and **Fig. 9**. To dimension Tangent Weighting, click the **Circular Spline handle** , **Fig. 8**. Then move the cursor out away from spline and click. Key-in 145 and press ENTER.

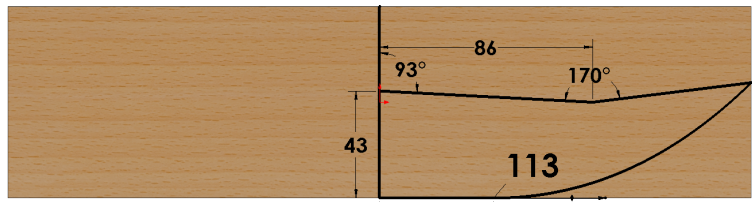

Fig. 7

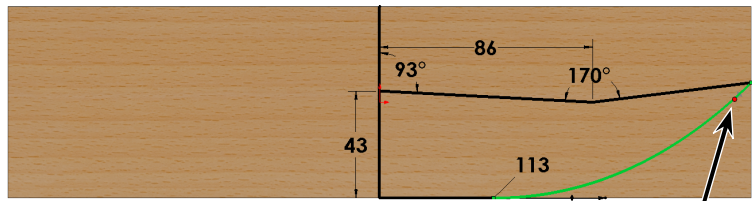

Fig. 8

Step 7. **Right click drawing and click Select** from menu to unselect Smart Dimension.

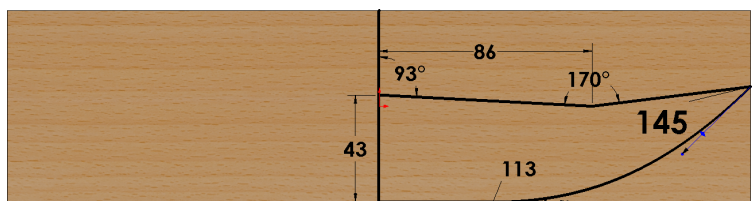

Fig. 9



Step 8. **Ctrl click the Circular Spline handle**  **of Spline Point 2 and the right edge of Wing** to select both, **Fig. 10**. Click **Make Collinear**  on the Property Manager, **Fig. 11**.



Fig. 10 Ctrl click Circular Spline Handle and edge

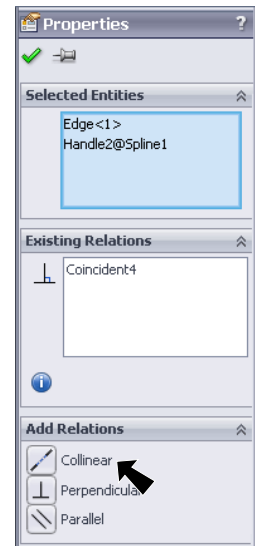

Fig. 11

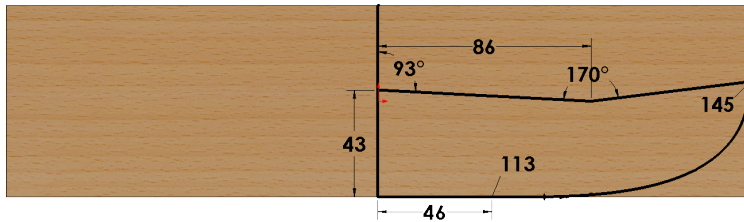
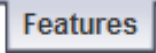

Fig. 12

E. Extruded Cut WING.

Step 1. Click **Features**  on the Command Manager toolbar.

Step 2. Click **Extruded Cut**  on the Features toolbar.

Step 3. In the Cut-Extrude Property Manager set:

under **Direction1**, **Fig. 13**

End Condition **Through All**

check **Flip side to cut**

uncheck **Direction 2**

under **Selected Contours**

click the **wing contour** in graphics area, **Fig. 14**.

The **Direction** arrow should point towards area to be cut away,

Fig. 14. If arrow is pointing in wrong direction, uncheck **Flip side to cut**, **Fig. 13**.

Click **OK** .

Step 4. Save. Use **Ctrl-S**.

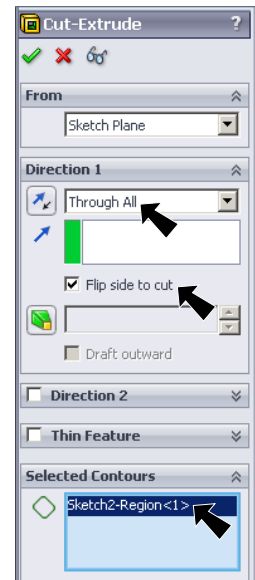
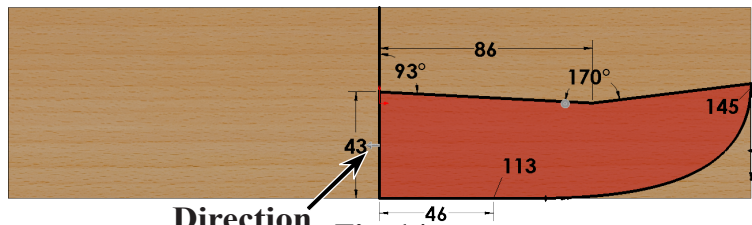

Fig. 13



Direction arrow **Fig. 14**

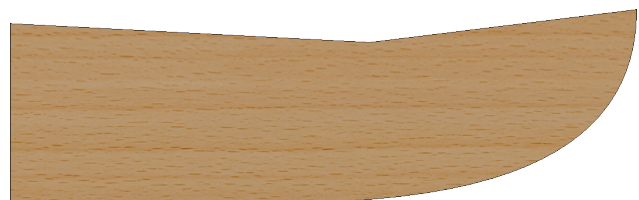





Fig. 15

F. Convert to Sheet Metal.

- Step 1. Click **Trimetric**  on the Standard Views toolbar.
- Step 2. Click Insert Menu > Sheet Metal > Convert To Sheet Metal.
- Step 3. In the Property Manager set:
 under Sheet Metal Parameters, **Fig. 16**
 in the Select a fixed entity box
 click the **top face of Wing**, **Fig. 17**
Sheet Thickness  **1.5**, **Fig. 16**
Default radius for bends  **2**
 click OK .

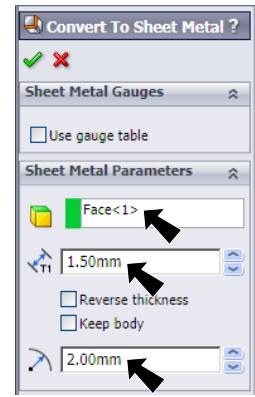

Fig. 16

G. Bend 1.

- Step 1. Click the **top face** and
 click **Sketch**  on the Content menu, **Fig. 18**.

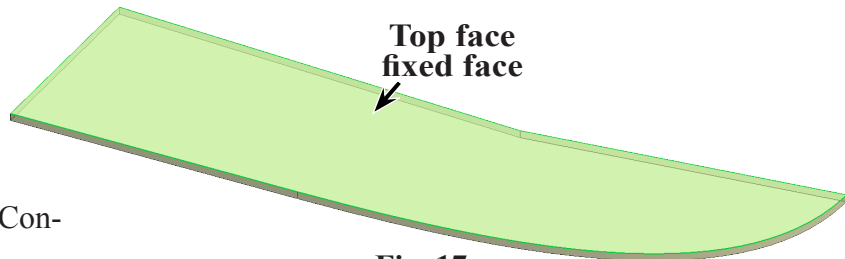



Fig. 17

- Step 2. Click **Normal To**  on the Standard Views toolbar. (Ctrl-8)

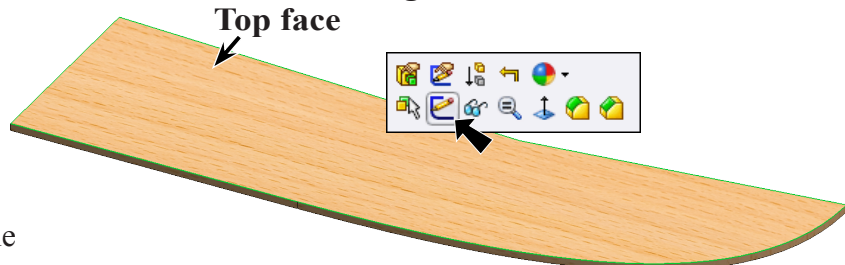



Fig. 18

- Step 3. Click **Line**  (L) on the Sketch toolbar.

- Step 4. Draw vertical line down sheet metal Wing, **Fig. 19**.
 Be use cursor changes to **Coincident/Vertical**  shape to confirm vertical line (relation) is created.

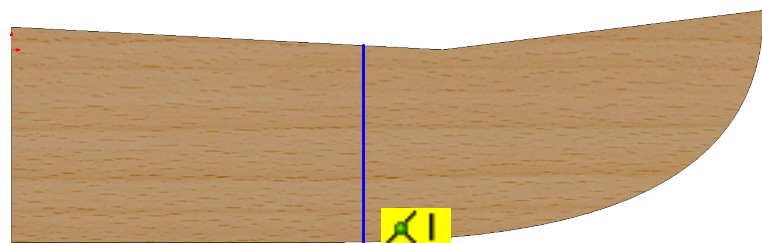



Fig. 19

- Step 5. Click **Smart Dimension**  (S) on the Sketch toolbar.

- Step 6. Add **86** dimension as shown in **Fig. 20**.

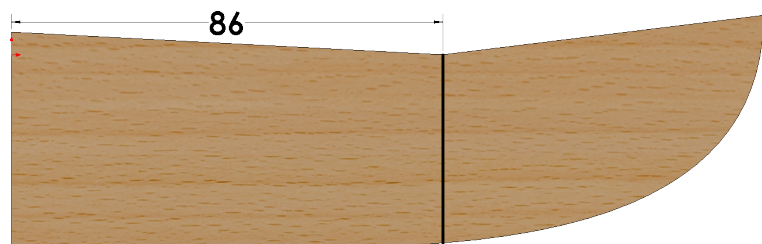

Fig. 20

Step 7. Click **Trimetric**  on the Standard Views toolbar.

Step 8. Click Insert Menu > Sheet Metal > Sketched Bend.

Step 9. In the Sketched Bend Property Manager set:

in the **Fixed Face**  box, **Fig. 21**
click the **top face of Wing**, **Fig. 22**

Bend position: Bend Centerline , **Fig. 21**
Bend Angle 18

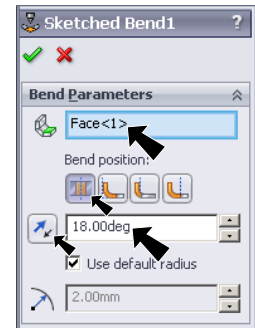

Fig. 21

The Direction arrow should point up, **Fig. 22**.
If arrow is pointing in wrong direction, click

Reverse Direction , **Fig. 21**.

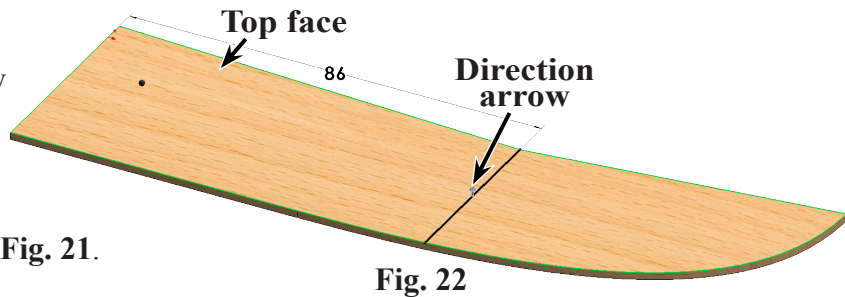

Fig. 22

Click **OK** , **Fig. 23**.

H. Bend 2.

Step 1. Click the **top face of outboard panel** and click **Sketch**  on the Content menu, **Fig. 23**.

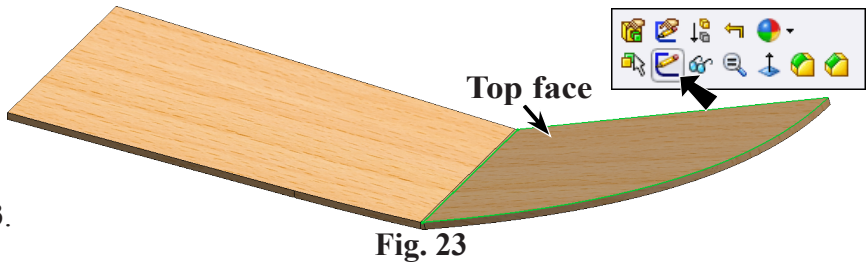



Fig. 23

Step 2. Click **Normal To**  on the Standard Views toolbar. (**Ctrl-8**)

Step 3. Click **Line**  (**L**) on the Sketch toolbar.



Step 4. Draw vertical line down sheet metal Wing, **Fig. 24**. Use the **Vertical**  icon to confirm line is vertical.



Fig. 24

Step 5. Click **Smart Dimension**  (**S**) on the Sketch toolbar.

Step 6. Add **42** dimension, **Fig. 25**.

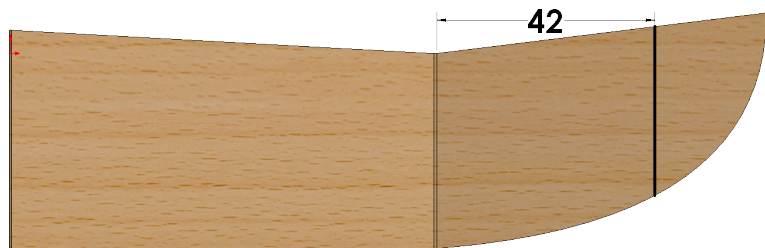

Fig. 25

Step 7. Click **Trimetric**  on the Standard Views toolbar.

Step 8. Click Insert Menu > Sheet Metal > Sketched Bend.

Step 9. In the Sketched Bend Property Manager set:

in the **Fixed Face**  box, **Fig. 26**
click the **top face outboard panel**, **Fig. 27**

Bend position: Bend Centerline , **Fig. 26**
Bend Angle 21

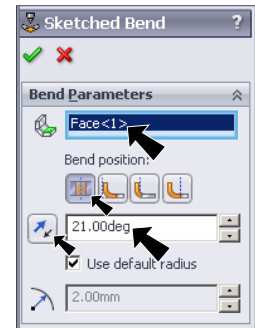

Fig. 26

The Direction arrow should point up, **Fig. 27**.
If arrow is pointing in wrong direction, click **Reverse Direction**

, **Fig. 26**.

Click OK ,
Fig. 28.

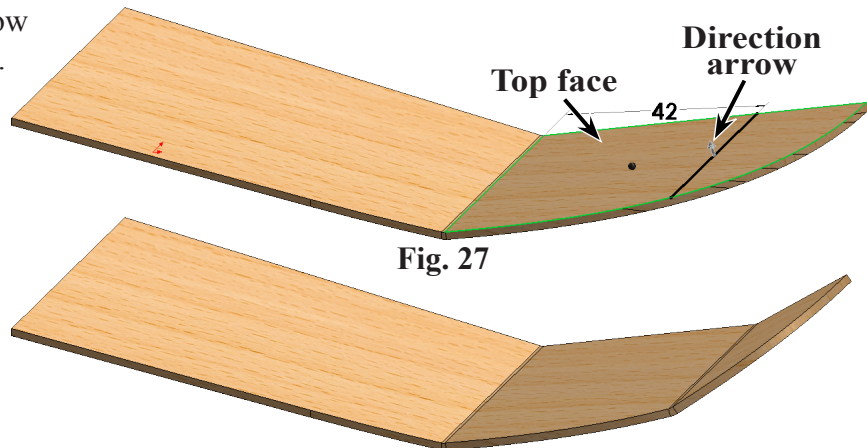

Fig. 27

Fig. 28

Step 10. Save. Use **Ctrl-S**.

I. Air Foil Sweep Cut Profile Sketch.

Step 1. Click **Right Plane**  in the Feature Manager and click **Sketch**  from the Content toolbar, **Fig. 29**.

Step 2. Click **Left**  on the Standard Views toolbar. (**Ctrl-4**)

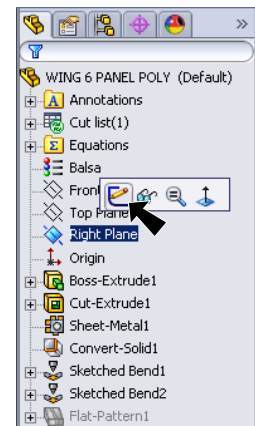

Fig. 29

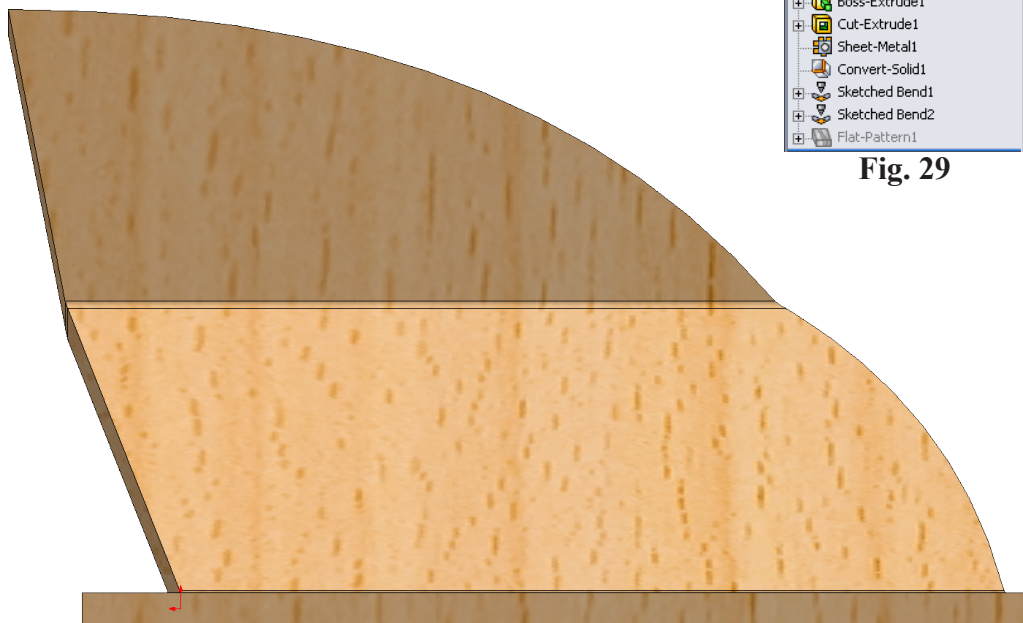

Fig. 30

Step 3. Click **Centerline**  in the **Line flyout**  (S) on the Sketch toolbar.

Step 4. Draw a centerline part way across the sketch, **Fig. 31**. Start from Midpoint  of trailing edge.



Fig. 31

Step 5. Click **Spline**  (S) on the Sketch toolbar.

Step 6. Draw a **2 Point Spline** from left end-point of centerline to top edge of Wing, **Fig. 32**. Press Escape to end spline.





Fig. 32

Step 7. Click **Smart Dimension**  (S) on the Sketch toolbar.

Step 8. Add the **20** dimension as shown in **Fig. 33**.



Fig. 33

Step 9. Click the Spline to select it and locate the **Circular Spline handle**  (small gray dot) of **Spline Point 1**, **Fig. 34**. To find the Circular spline handle, start your cursor at the bottom Spline Point, Spline Point 1 and move cursor up along the spline. The Spline Point the Circular Spline handle will highlight as a red circle .

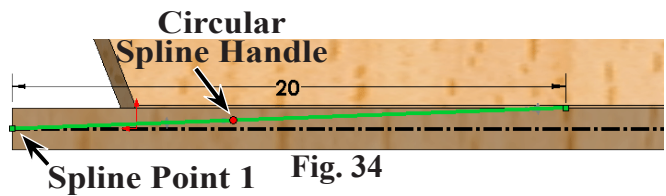

Fig. 34



Step 10. Dimension Spline Point 1 **Tangent Weighting 20**, **Fig. 35**. To dimension Tangent Weighting, click the **Circular Spline handle** , then move the cursor out away from spline and click. Key-in 20 and press ENTER.



Fig. 35

Step 11. Dimension Spline Point 1 **Tangent Radial Direction 3.6 degrees**, **Fig. 36**. To dimension Tangent Radial Direction, click the **Circular Spline handle**  **and centerline**, then move cursor between and click. Key-in 3.6 and press ENTER.

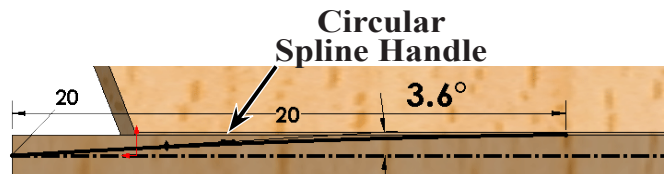
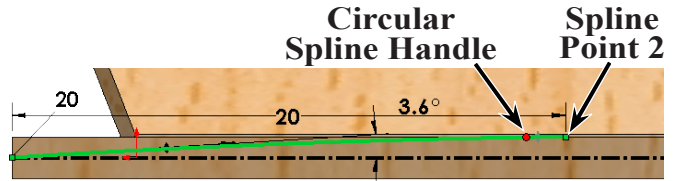
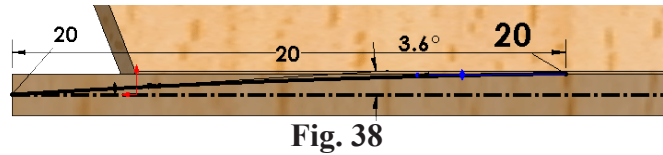

Fig. 36

Step 12. Click Spline to display the Circular Spline handle and locate the **Circular Spline handle** of **Spline Point 2**, **Fig. 37**.



Step 13. Dimension Spline Point 2 **Tangent Weighting1 20**, **Fig. 38**. To dimension Tangent Weighting, click the **Circular Spline handle**, then move the cursor out away from spline and click. Key-in 20 and press ENTER.



Step 14. **Right click drawing and click Select** from menu to unselect Smart Dimension.

Step 15. **Ctrl click the Circular Spline handle** of **Spline Point 2** and the **top edge of Wing** to select both, **Fig. 39**. Click **Make Collinear** on the Property Manager, **Fig. 40**.

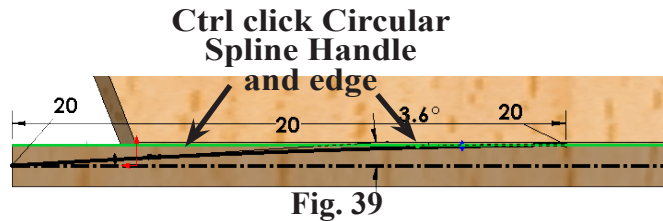

Step 16. **Drag selection around the sketch** to select all entities, **Fig. 41**. To drag selection, click **below** and to right of sketch and drag up and to left to drag around all.

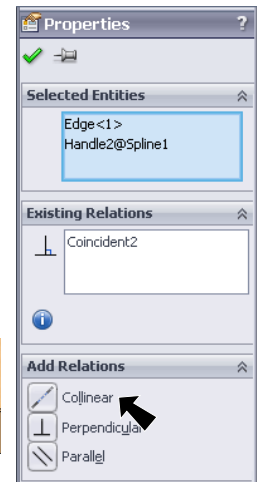
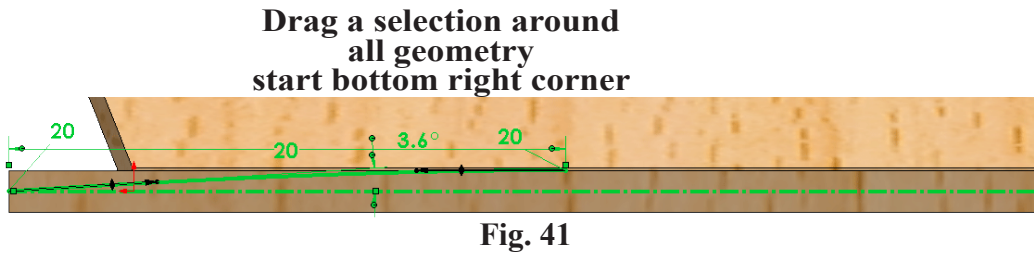

Step 17. Click **Mirror Entities** on the Sketch toolbar.

Step 18. Click **Line** (L) on the Sketch toolbar.

Step 19. Draw **7 lines**, **Fig. 42**. Draw lines starting from the endpoint of spline around Wing. I changed color of two lines for clarity. You don't need to change color.

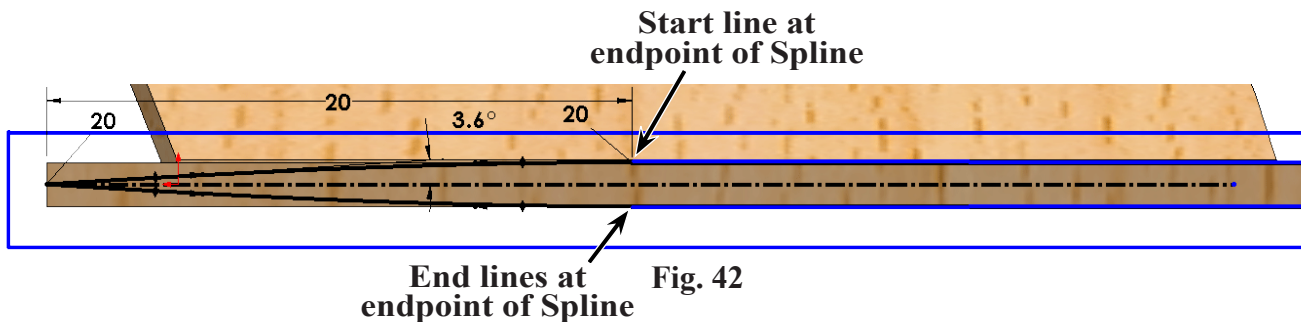

Step 20. Click **Smart Dimension**  (S) on the Sketch toolbar.

Step 21. Add the Dimensions as shown in **Fig. 43**.

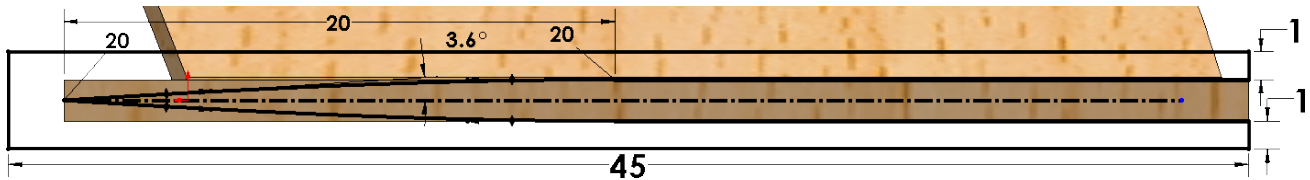



Fig. 43

Step 22. Click **Exit Sketch**  on the Sketch toolbar.

Step 23. Save. Use **Ctrl-S**.

J. Air Foil Sweep Cut Path Sketch.

Step 1. Rotate view to view **along trailing edge** as shown in **Fig. 44**. Hold down middle mouse button (wheel) and drag.

Step 2. Click Insert Menu > Curve > Composite.

Step 3. In the Property Manager set: for Entities to Join, **Fig. 45** click **edges along trailing edge**, **Fig. 44** and **Fig. 46**. If necessary, zoom in.

Click OK .

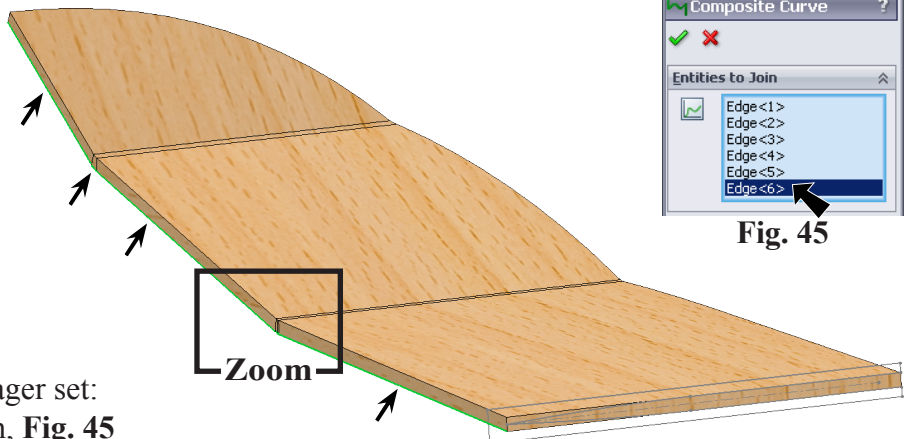

Fig. 45

Fig. 44

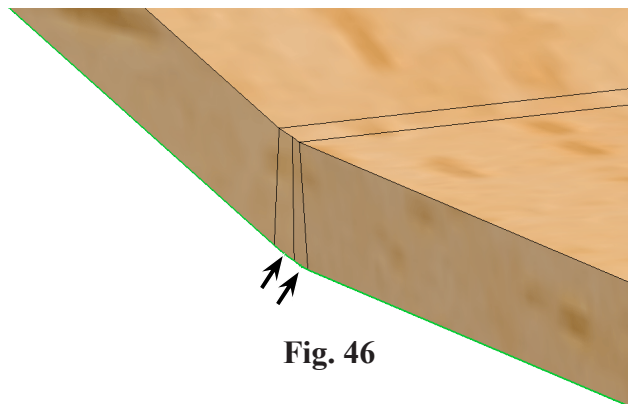
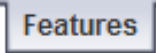



Fig. 46

K. Air Foil Sweep Cut.

Step 1. **Ctrl** click both **Sketch5** and **Composite Curve** in the Feature Manager to select both, **Fig. 47**.

Step 2. Click **Features**  on the Command Manager toolbar.

Step 3. Click **Swept Cut**  on the Features toolbar.

Step 4. In the Cut Swept Property Manager set:

Profile  and **Path**  were preselected under Options

Orientation/twist type: **Keep normal constant**, **Fig. 48**

click **OK** .

Step 5. If necessary hide sketch. To hide, **click Sketch5** in graphics area and **click Hide**  on the Content menu, **Fig. 50**.

Step 6. Save. Use **Ctrl-S**.

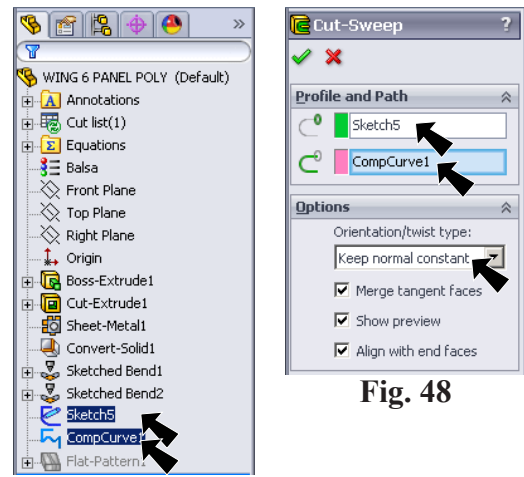

Fig. 47

Fig. 48

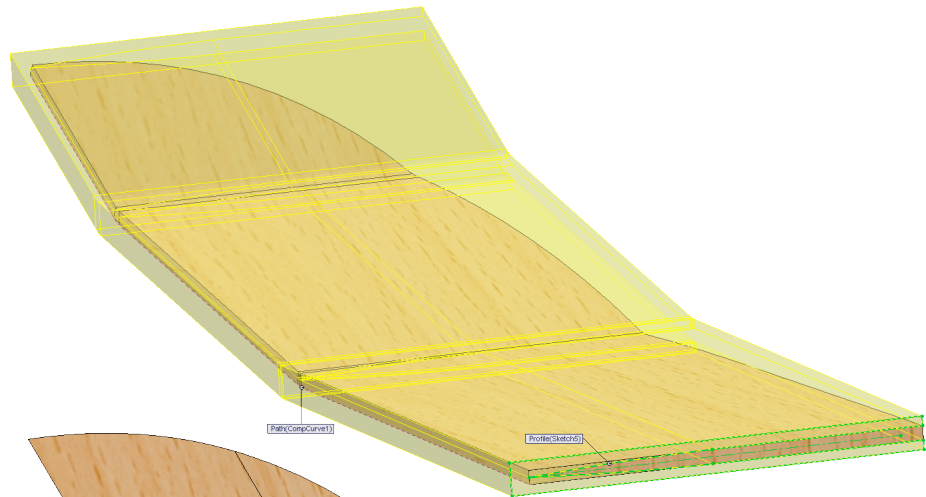

Fig. 49

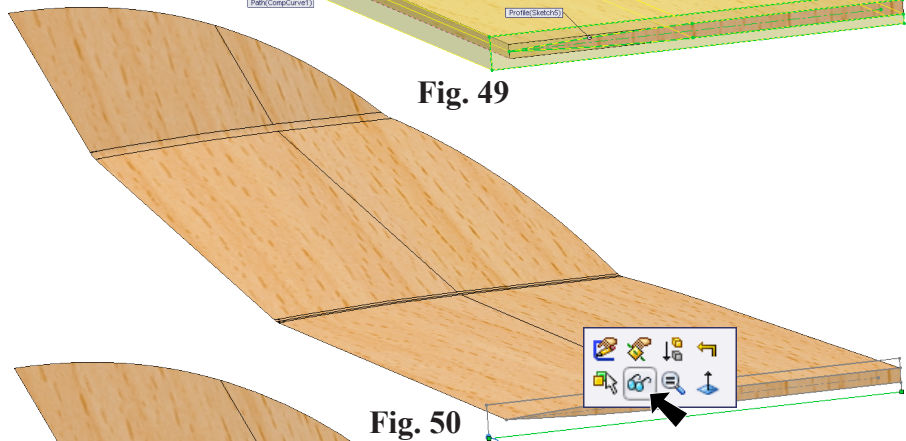

Fig. 50

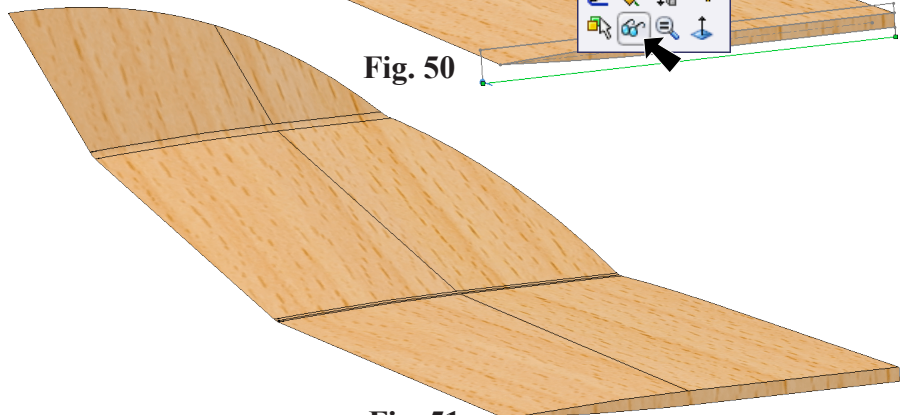

Fig. 51

L. Fillet Face 1.

Step 1. Click **Trimetric**  on the Standard Views toolbar.

Step 2. Click **Fillet**  on the Features toolbar.

Step 3. In the Fillet Property Manager, select **Manual**, **Fig. 52** under Fillet Type select **Face fillet**

Radius  .5

click in the **Face Set 1**  box

click **flat top face of inboard panel**, **Fig. 53**

click in the **Face Set 2**  box, **Fig. 52**

click **front face inboard panel**, **Fig. 53**

click **OK** , **Fig. 54.**

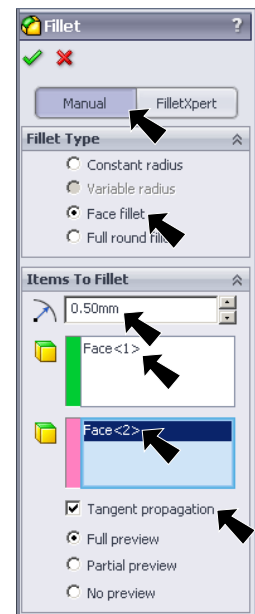

Fig. 52

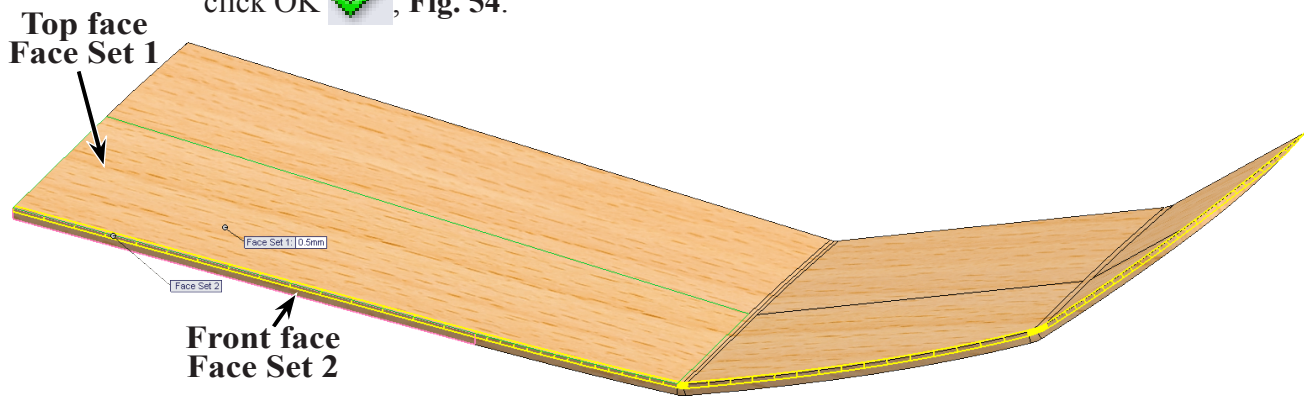

Fig. 53

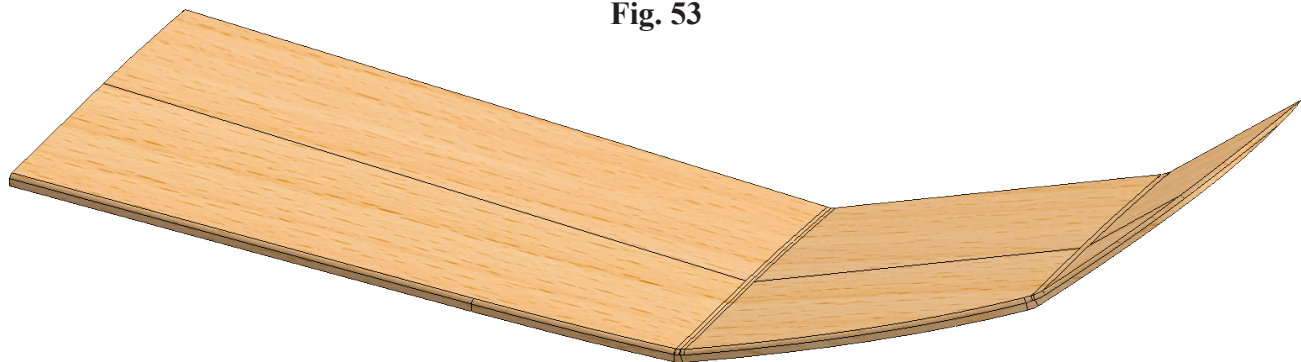

Fig. 54



M. Fillet Face2.

Step 1. Click **Fillet**  on the Features toolbar.

Step 2. In the Fillet Property Manager, select **Manual**, **Fig. 55** under Fillet Type select **Face fillet**

Radius  **.5**
 uncheck **Tangent propagation**

click in the **Face Set 1**  box
 click **front faces all across leading edge**, **Fig. 56**

click in the **Face Set 2**  box, **Fig. 55**
 rotate view to view **bottom faces**, hold down middle mouse button (wheel) and drag to rotate view, **Fig. 57**
 click **bottom faces across wing**, **Fig. 57**
 click OK , **Fig. 58.**

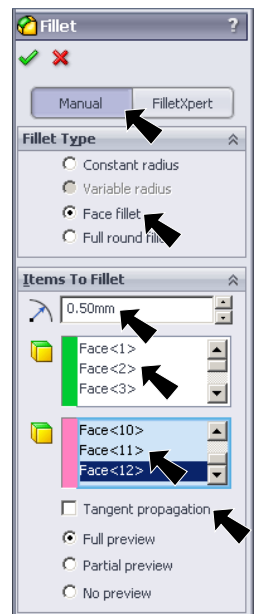
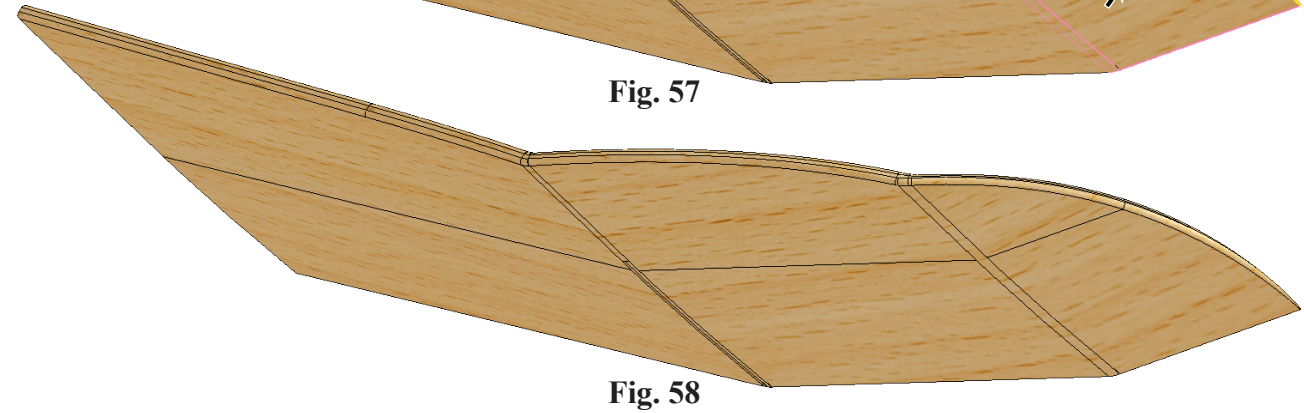
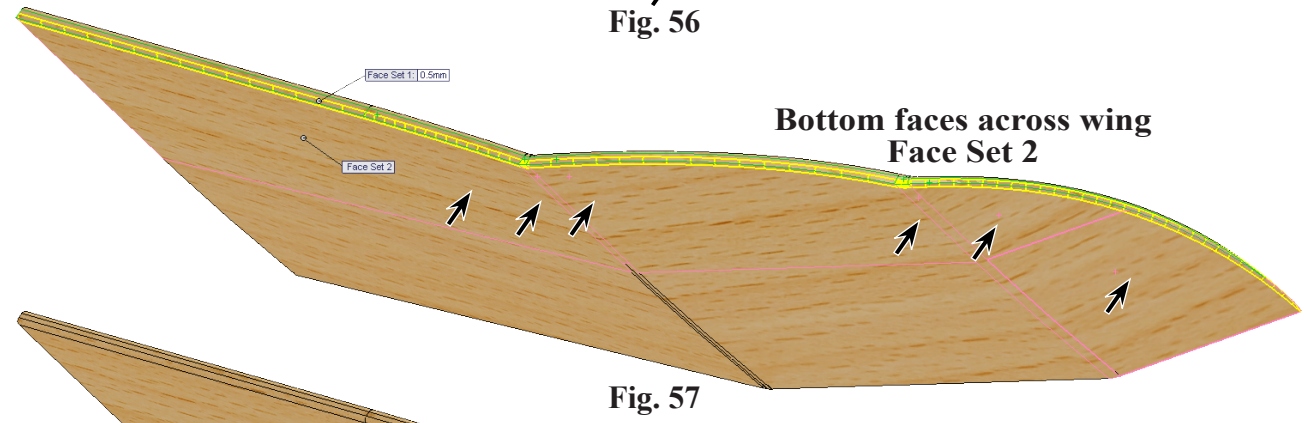
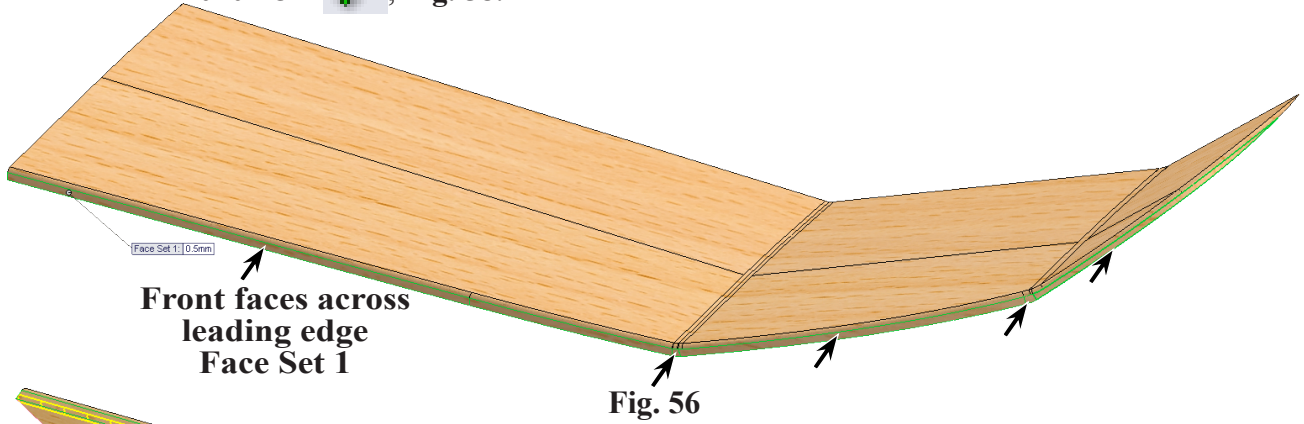





Fig. 55



N. Chamfer Dihedral Angle.

Step 1. Click **Trimetric**  on the Standard Views toolbar.

Step 2. Click **Cut-Sweep1** in the Feature Manager and click **Roll Back**  from the Content toolbar, **Fig. 59**.

Step 3. Click **Chamfer**  in the **Fillet flyout**  on the Features toolbar.

Step 4. In the Chamfer Property Manager set:
click **top root edge**, **Fig. 61**

Depth  **1.5**, **Fig. 60**

Angle  **6°**

The Direction arrow should point down, **Fig. 61**. If arrow is pointing in wrong direction, check **Flip direction**.

Select **Full preview**.

Click OK .

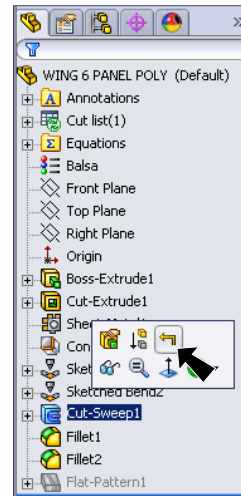

Fig. 59

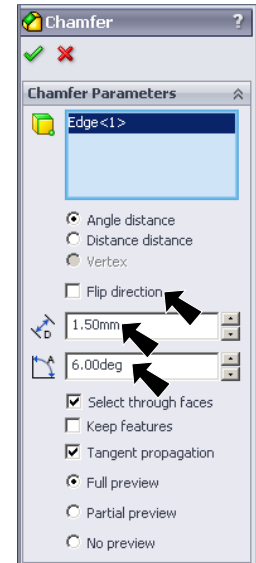

Fig. 60

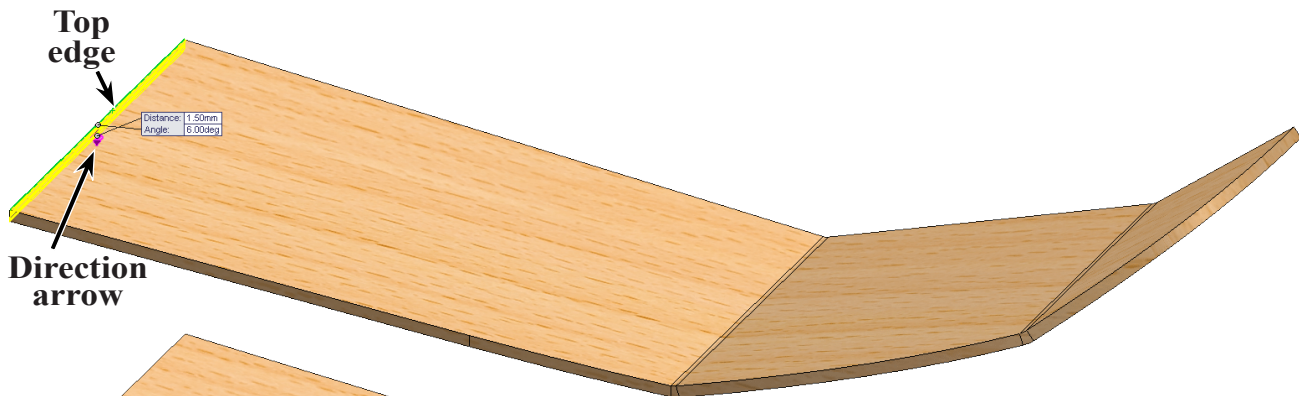

Fig. 61

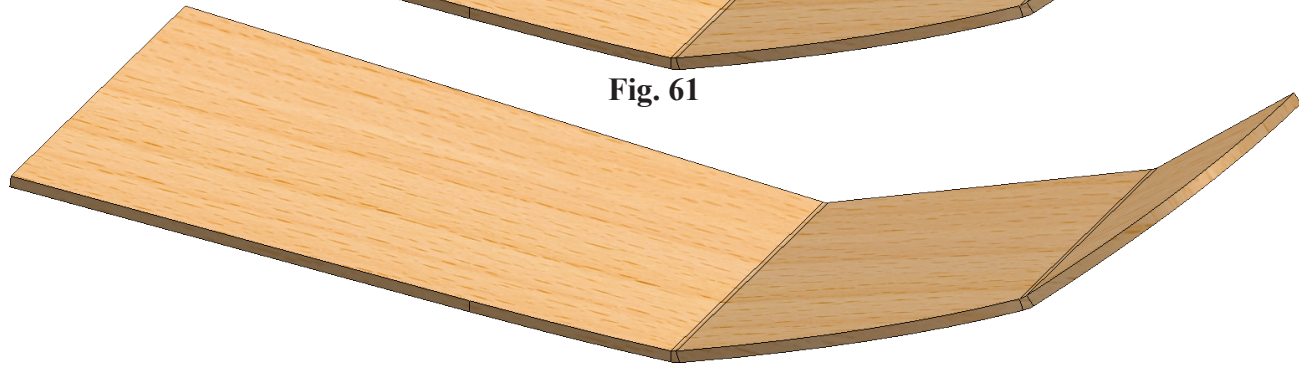

Fig. 62

Step 5. **Right click Cut-Sweep1** in the Feature Manager and click **Roll to end** from menu, **Fig. 63**.

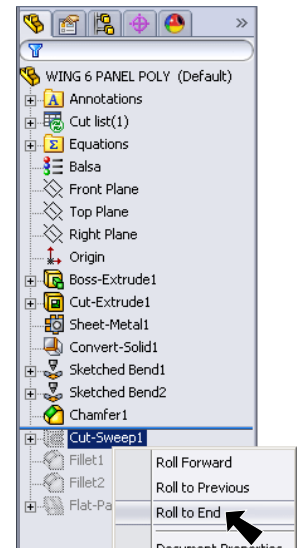

Fig. 63

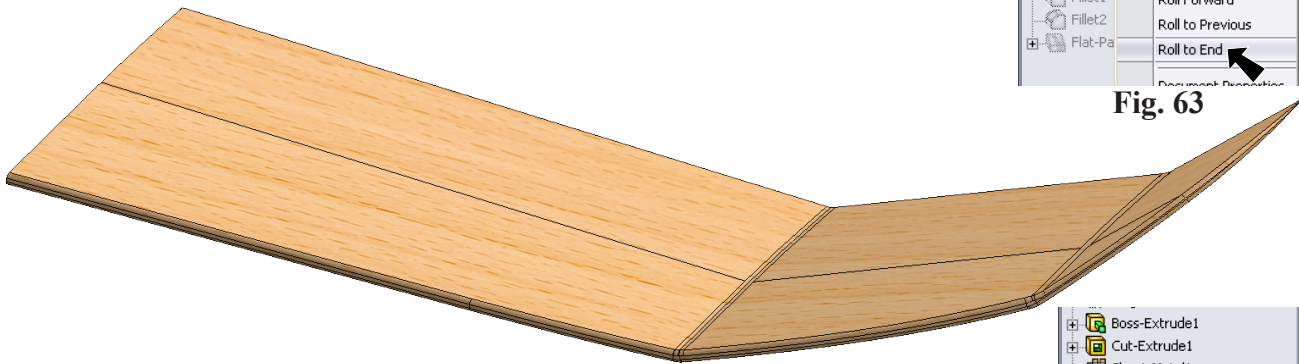



Fig. 64

O. Flatten Sheet Metal.

Step 1. The Sheet Metal will flatten with the Cut-Sweep and Fillets suppressed. **Ctrl click** the Cut-Sweep1 and both Fillets, release the Ctrl key and click **Suppress**  from menu, **Fig. 65**.

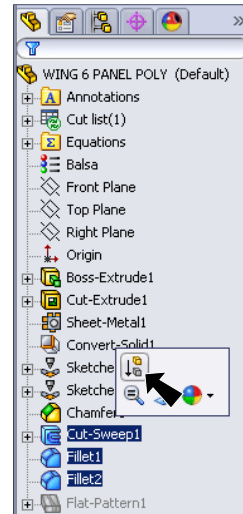



Fig. 65

Step 2. To Flatten, click the **Flat-Pattern1** feature in the Feature Manager and click **Unsuppress**  in the menu, **Fig. 66** and **Fig. 67**.

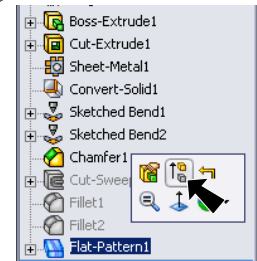



Fig. 66

Step 3. To return part to bent state, click the **Flat-Pattern1** feature and click **Suppress**  in the menu, **Fig. 68**. Then, **unsuppress** the Cut-Sweep1 and both Fillets, **Fig. 69**.

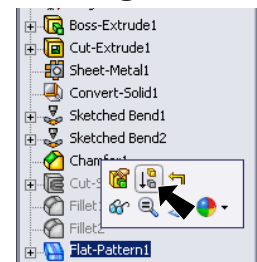

Fig. 68

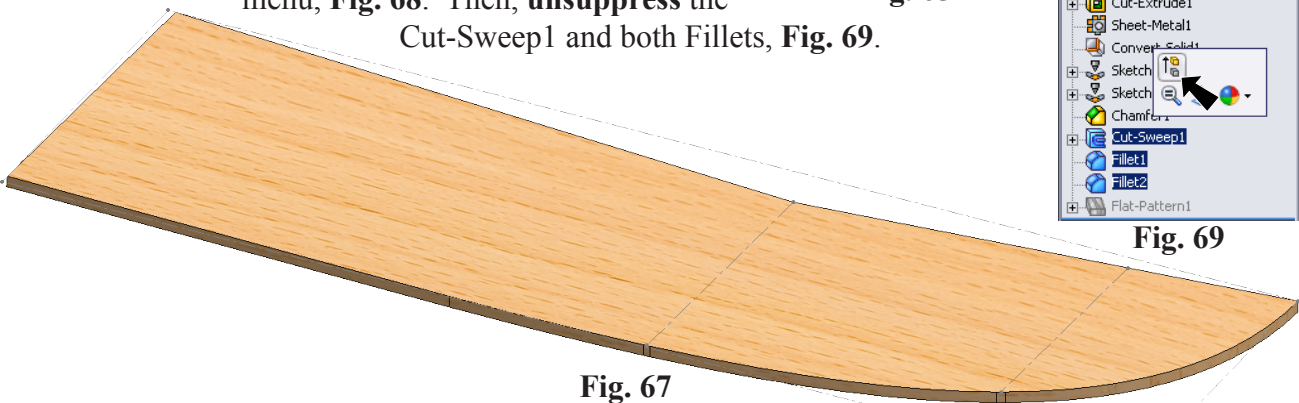

Fig. 67

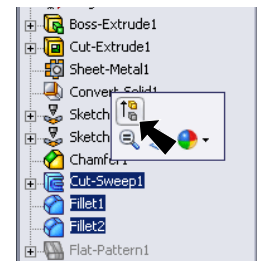

Fig. 69